

# TEQUILA Achievements



Traffic Engineering for Quality of Service in the Internet at Large

<http://www.ist-tequila.org>

David Griffin  
*University College London*



# Tequila Consortium

---

- Industrial Partners

- Alcatel, Belgium
- Algosystems S.A., Greece
- France Telecom-R&D, France
- Global Crossing, UK

- Universities

- NTUA - National Technical University of Athens, Greece
- UCL - University College London, UK
- UniS - The University of Surrey, UK

- Research Institutes

- IMEC, Belgium
- TERENA, Netherlands



# TEQUILA Presentations

---

## **TEQUILA Traffic Engineering System Results**

Prof. George Pavlou

*University of Surrey, UK*

## **TEQUILA Service Management System Results**

Eleni Mykoniati

*National Technical University of Athens, Greece*

## **UK Testbed: MPLS Traffic Engineering Results**

Richard Egan

*Global Crossing, UK*



---

# **TEQUILA Traffic Engineering System Results**

Prof. George Pavlou

*University of Surrey, UK*



---

# **TEQUILA Service Management System Results**

**Eleni Mykoniati**

*National Technical University of Athens, Greece*



# **UK Testbed: MPLS Traffic Engineering Results**

Richard Egan  
*Global Crossing, UK*



## TEQUILA conclusions

---

- TEQUILA has proposed and validated solutions for intra-domain QoS in the Internet
- In the opinion of the partners, TEQUILA has been a great success
- Results have been publicised



## TEQUILA conclusions

---

- **TEQUILA has proposed and validated solutions for intra-domain QoS in the Internet**
  - ...from SLS requirements through traffic engineering in a diffserv environment, satisfying customers' QoS demands
- In the opinion of the partners, TEQUILA has been a great success
- Results have been publicised



## TEQUILA conclusions

---

- TEQUILA has proposed and validated solutions for intra-domain QoS in the Internet
- **In the opinion of the partners, TEQUILA has been a great success**
  - All milestones have been met
  - All deliverables produced
  - The project's objectives have been fully achieved
  - Results are of significant value
- Results have been publicised



## TEQUILA conclusions

---

- TEQUILA has proposed and validated solutions for intra-domain QoS in the Internet
- In the opinion of the partners, TEQUILA has been a great success
- **Results have been publicised**
  - All specifications (architecture, templates, algorithms and protocols) have been made public (D3.4)
  - Full set of experimental results have been released (D3.4)
  - ~10 Internet drafts plus very popular SLS BOF session at IETF 49
  - ~30 papers in journals or well-regarded conferences (several more in the pipeline)
  - Two TEQUILA-organised workshops



<http://www.ist-tequila.org>



---

# TEQUILA Traffic Engineering System Results

**Prof. George Pavlou**  
**Centre for Communication Systems Research**  
**University of Surrey, UK**  
**G.Pavlou@eim.surrey.ac.uk**

**TEQUILA Consortium**

# Service Level Specifications

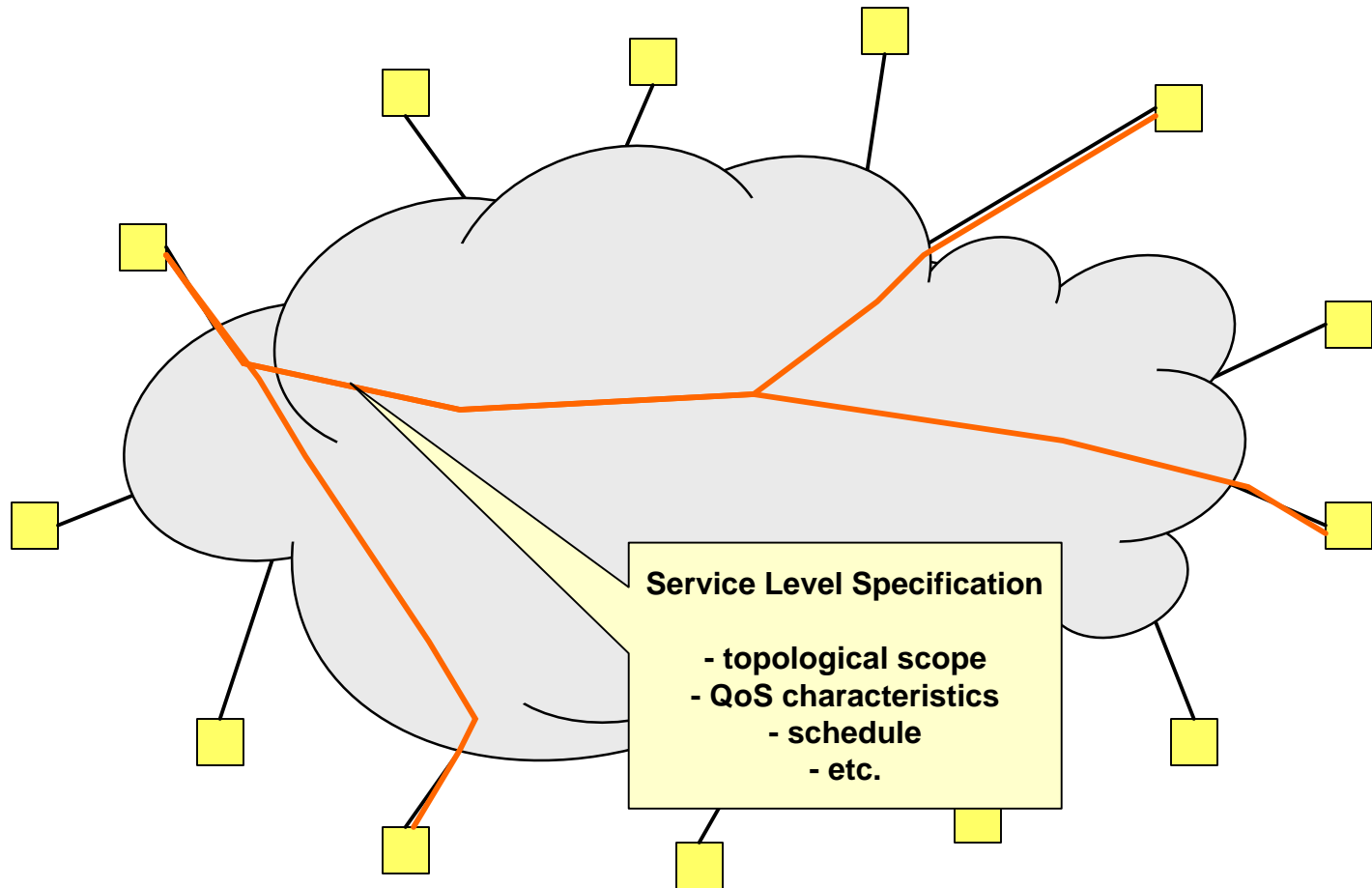

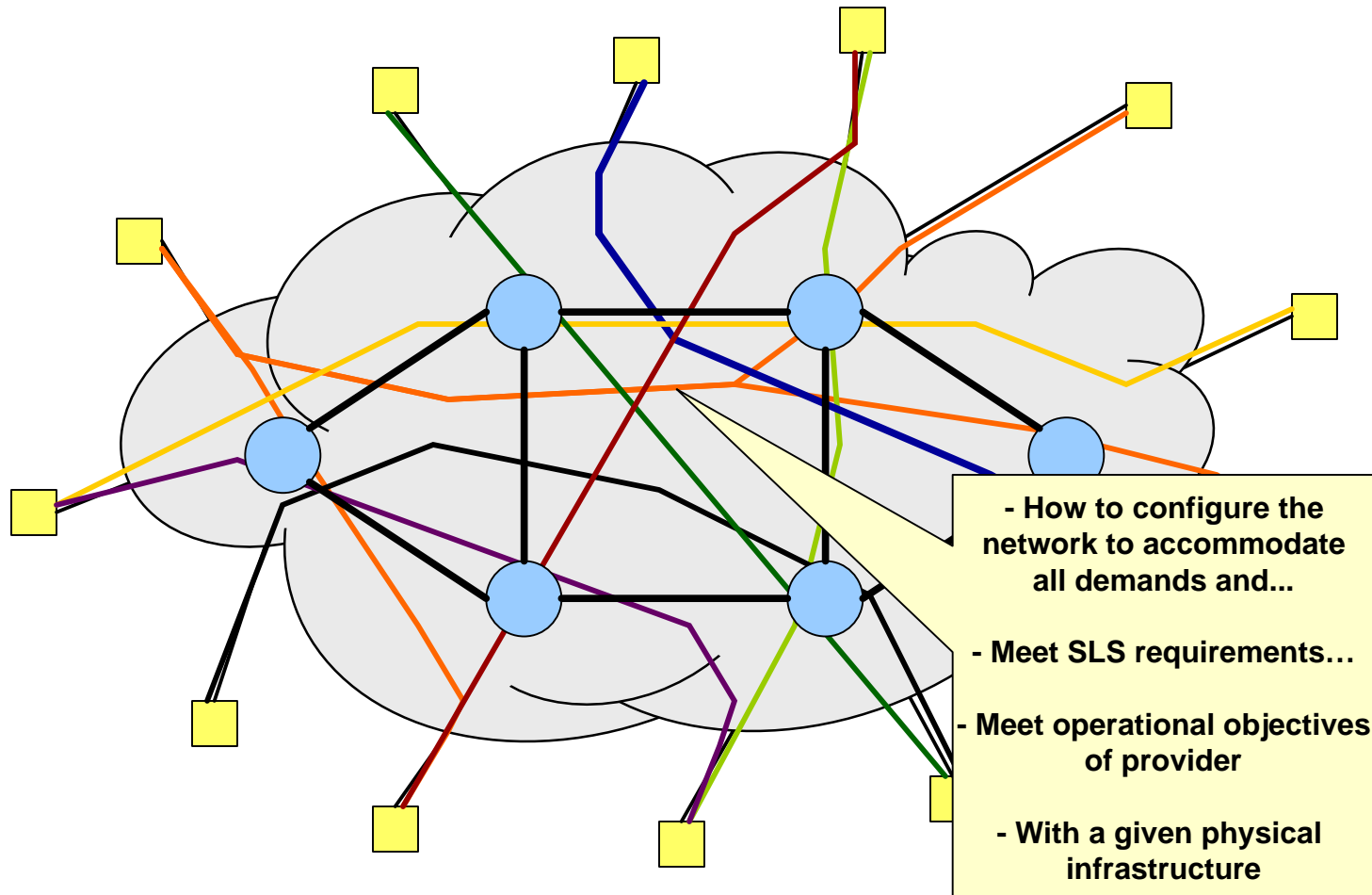



# Functional Architecture for Quality of Service

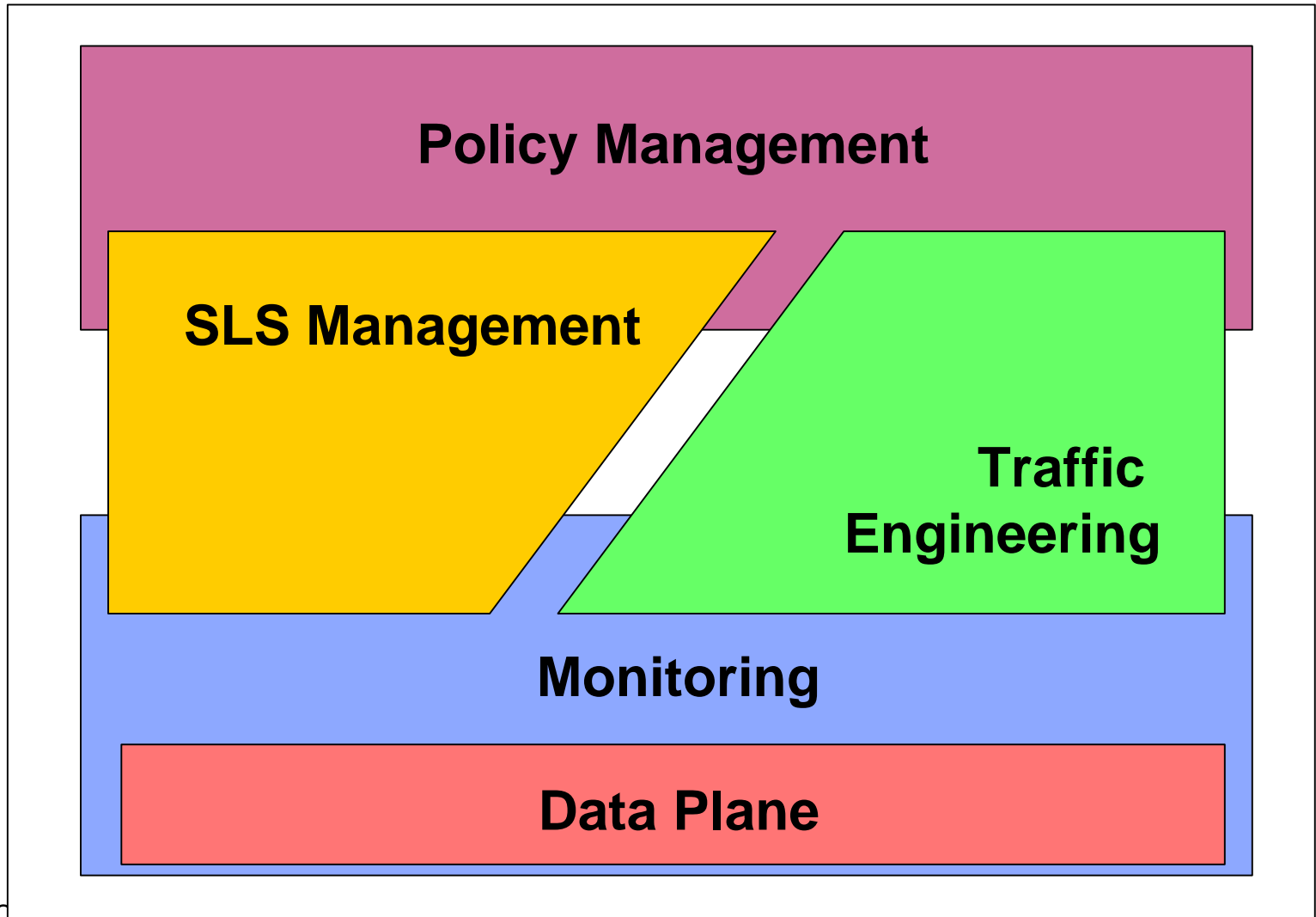



# Resource Provisioning Cycle

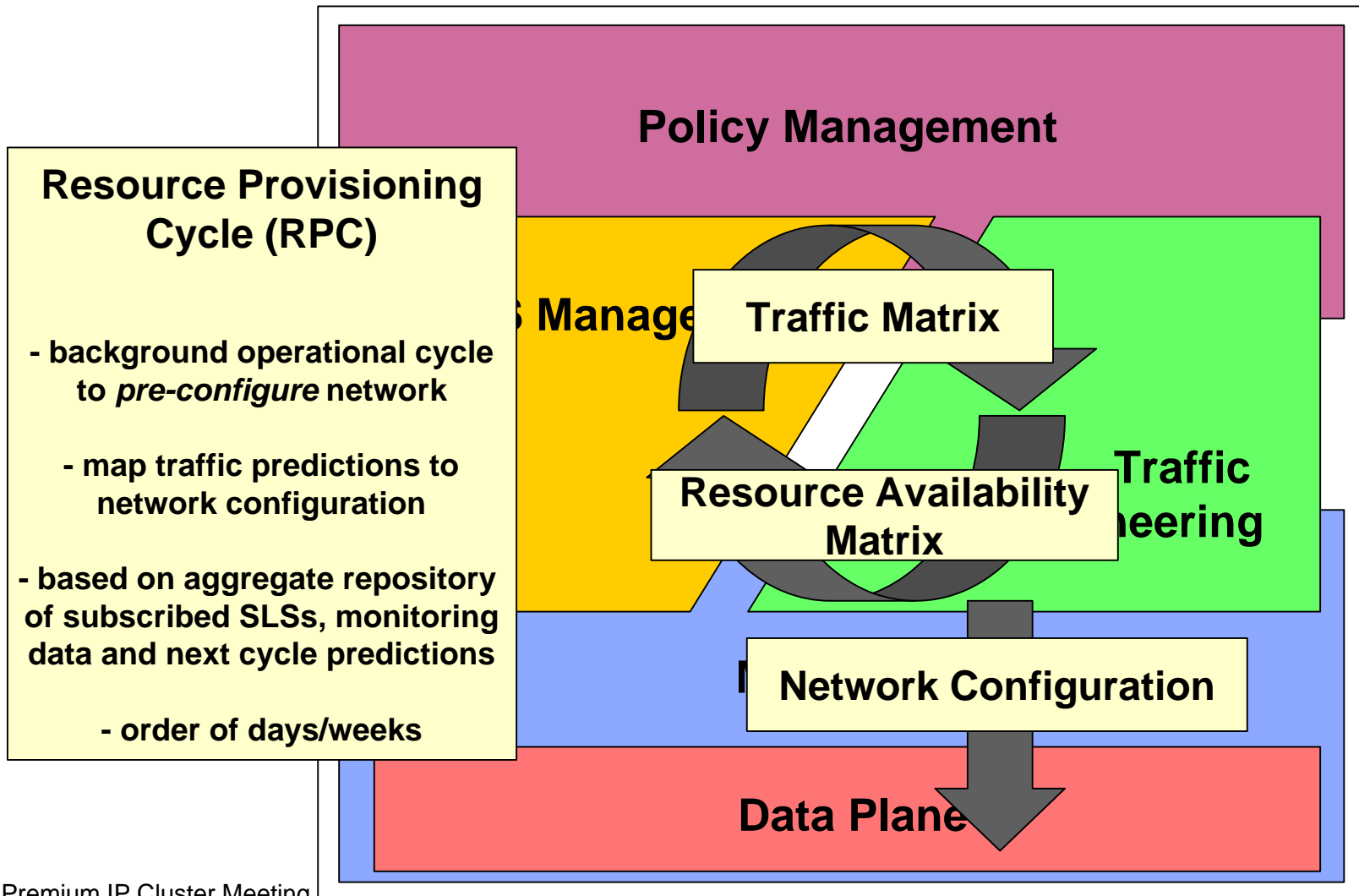



# Detailed Architectural View

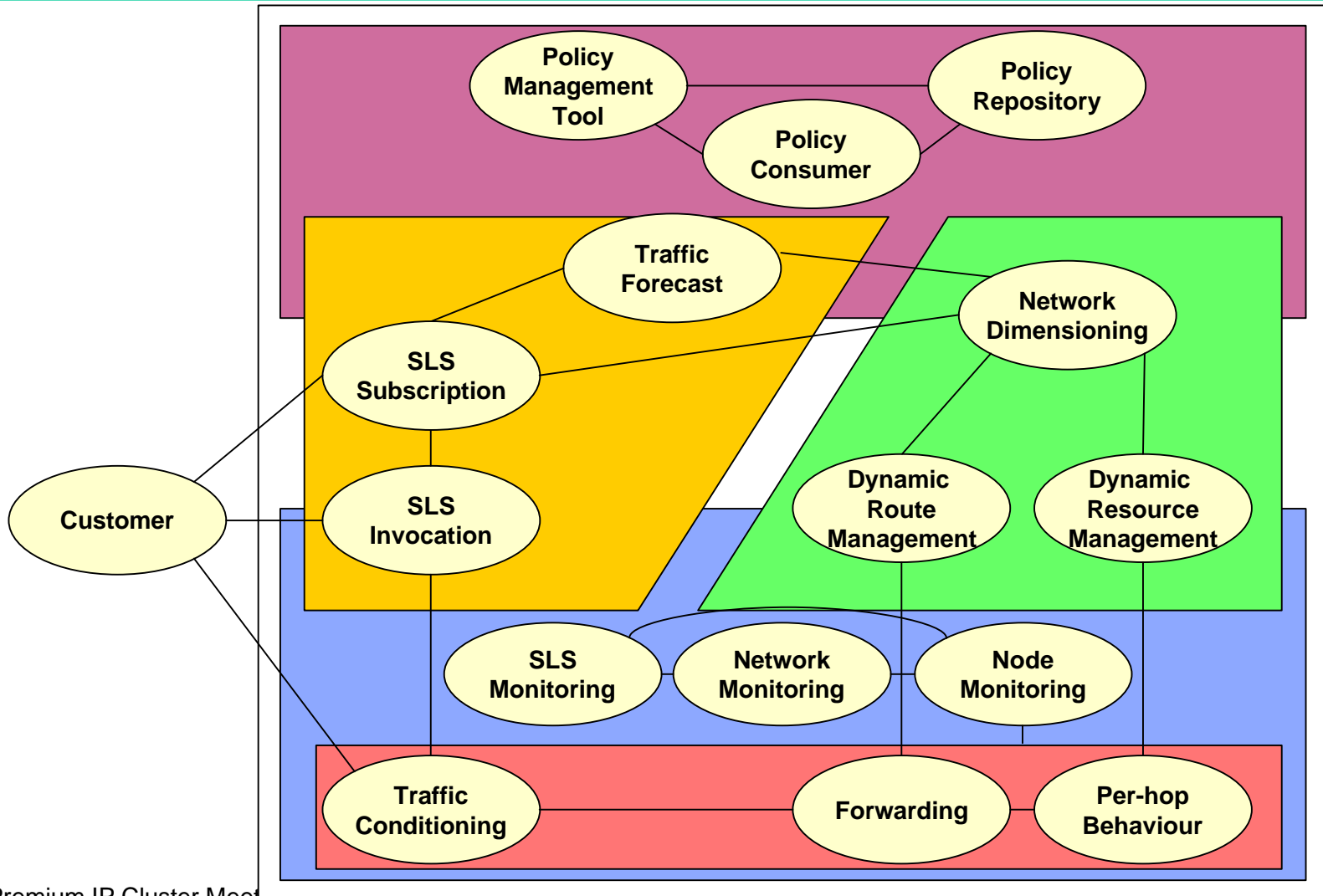



# Focus on Traffic Engineering

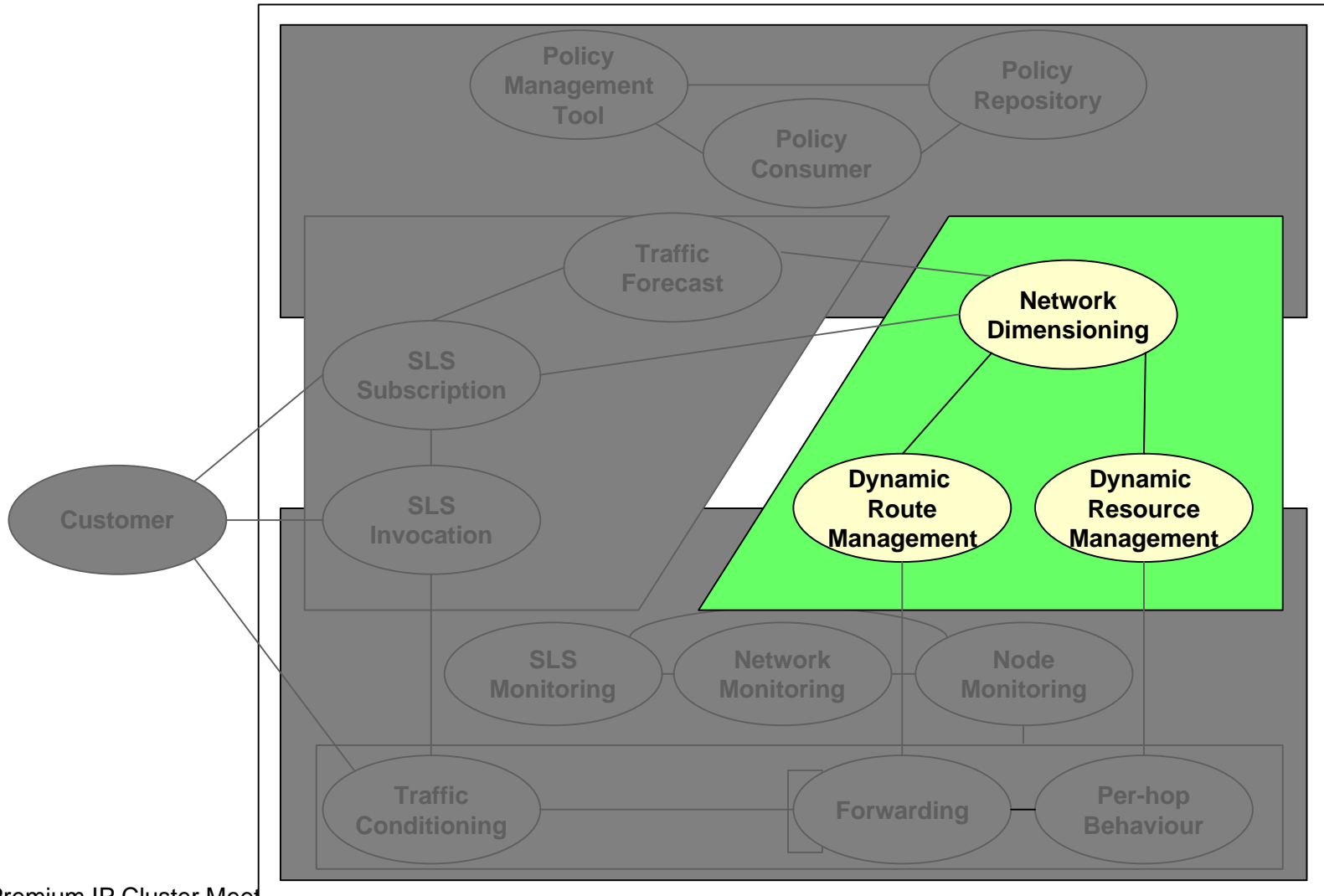

- **Traffic Trunk (TT): aggregation of flows with similar edge-to-edge QoS requirements (i.e. of the same QoS class)**
  - **Ingress, set of egresses**
    - pipe (1:1) or hose (1:N) model
  - **General case the hose model**
    - results in a tree with logically associated “tree bandwidth”
    - bandwidth savings compared to multiple pipe trunks

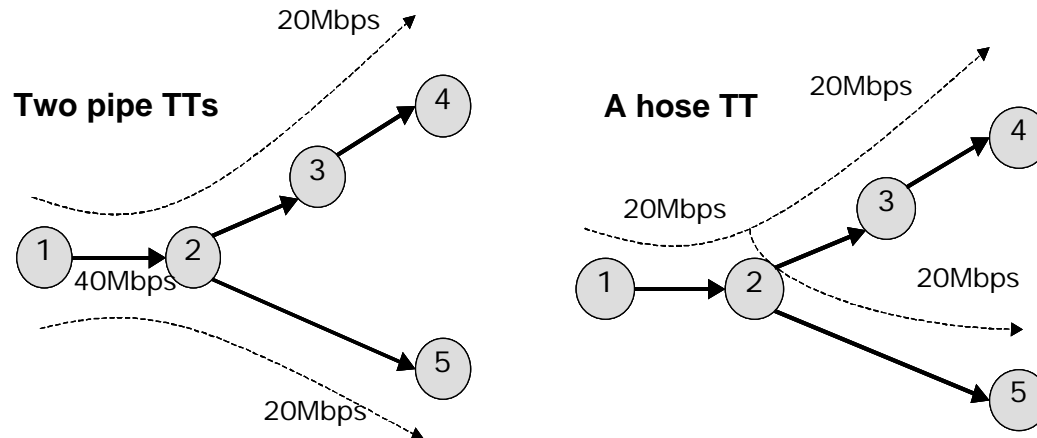



# Two-Level Approach

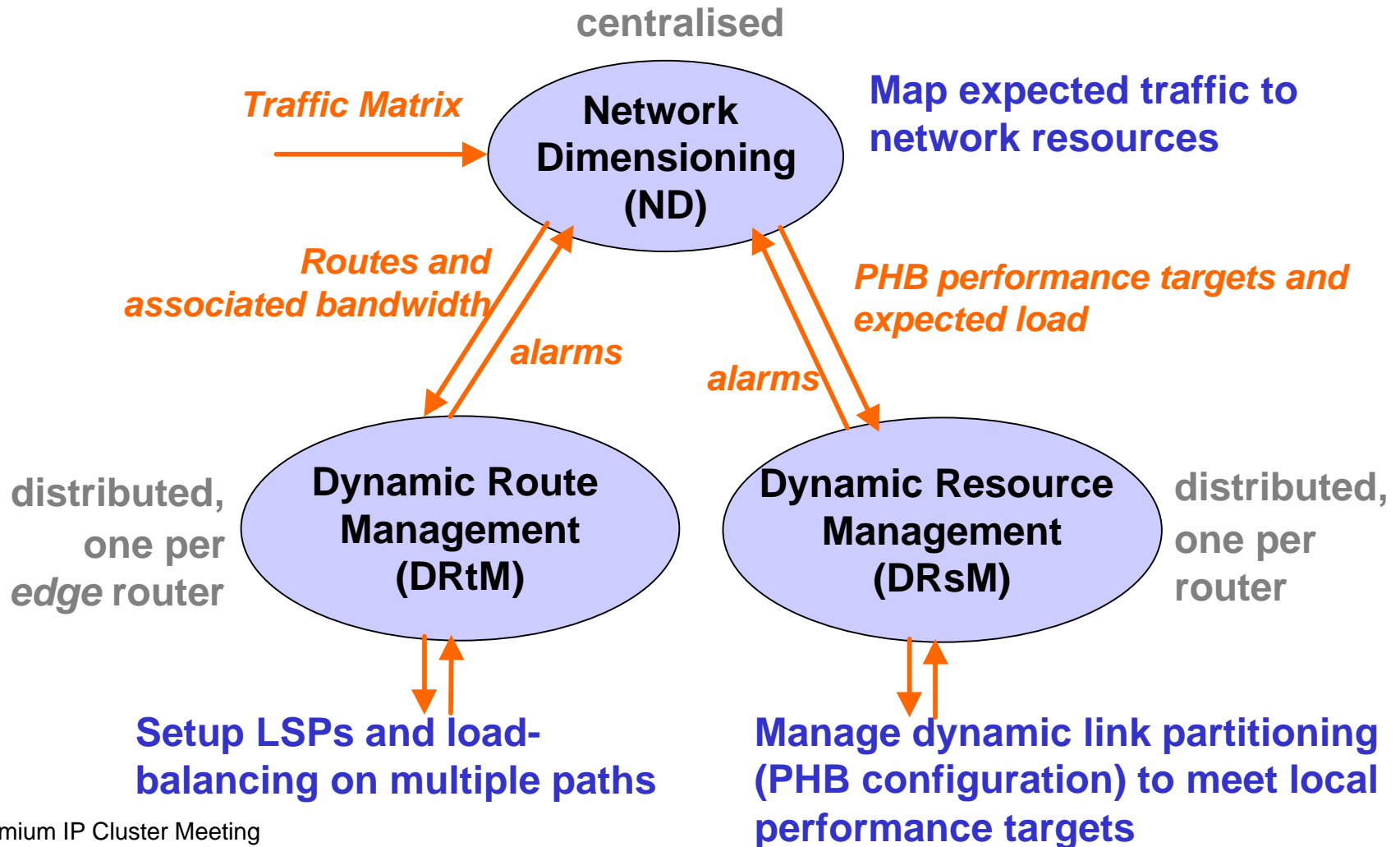



# Network Dimensioning: Model and Objectives

---

---

- **Primary objective: meet Traffic Trunks' QoS requirements**
- **Avoid overloading parts of the network while other parts are under-utilised**
- **Achieve overall low network load (cost)**
- **Link cost function**
  - **Continuous increasing function of the link load of each traffic class**
  - **Potentially different functions for different traffic classes**



# Optimisation Approach

---

- **Solution-based on an iterative procedure**
  - Start with an initial feasible path vector (TT allocation) based on shortest paths
  - Improve gradually this solution moving towards a *feasible* and *descent* direction by shifting capacity to “better” paths
  - Improve overall cost function
- **Gradient projection method**
  - Non-linear unconstrained optimisation
  - Move along the negative of the gradient vector
- **At each step, a **constrained shortest path** algorithm is used for pipe trunks and a **constrained Steiner tree** algorithm for hose trunks**
  - The algorithms are **constrained due to delay & loss bounds**, translated to a **hop count constraint**



# TEQUILA MWHCT Constrained Steiner Tree Algorithm

---

- Dijkstra's algorithm is used for shortest paths
- A number of constrained Steiner Tree algorithms exist:
  - Bounded Shortest Multicast Algorithm (BSMA)
  - Kompella, Pasquale and Polyzos (KPP) algorithm
  - QoS Dependent Multicast Routing (QDMR) algorithm
  - Constrained Dijkstra (CDKS) algorithm
- BSMA is best in terms of cost but computationally expensive
- We thought we could **better BSMA** in terms of cost and be much more computationally efficient
  - Designed the **Minimum Weight Hop-Count Constraint Tree (MWHCT)** algorithm
  - Improved it further in a subsequent version (MWHCT-v2)
- We present results comparing it to the above algorithms



# 50 node network, min branch bandwidth 45 Mbps, max 85 Mbps

Max Hop  
Count 8

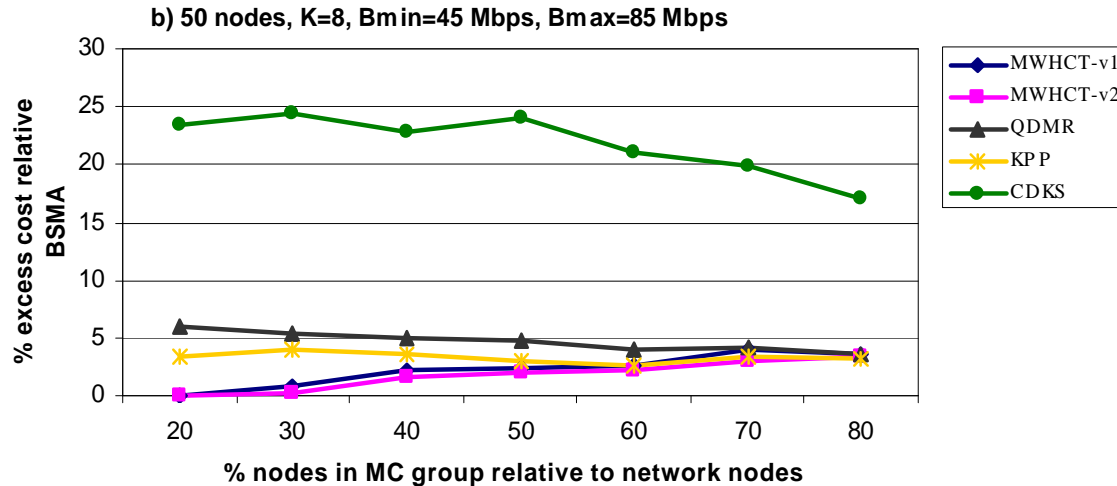

Max Hop  
Count 15

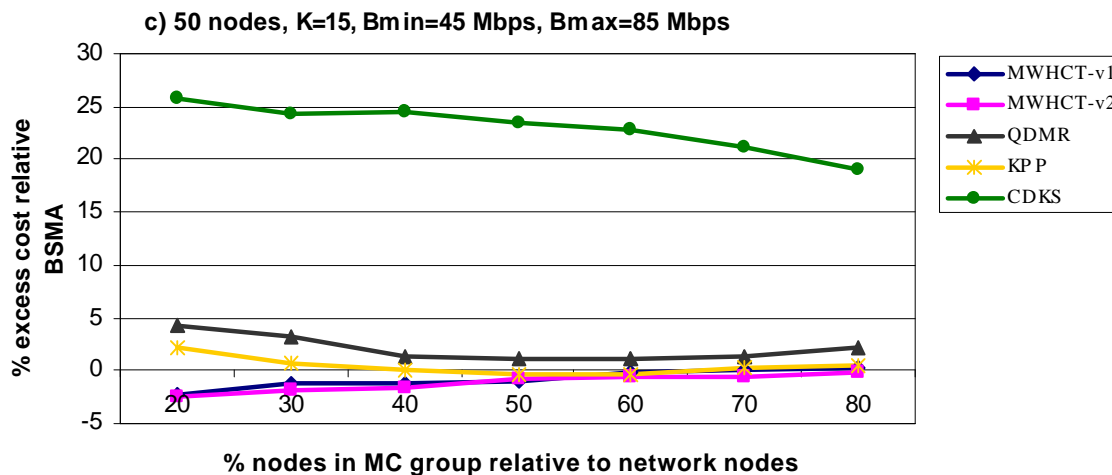



# Execution time comparison for the previous scenario

Max Hop  
Count 8

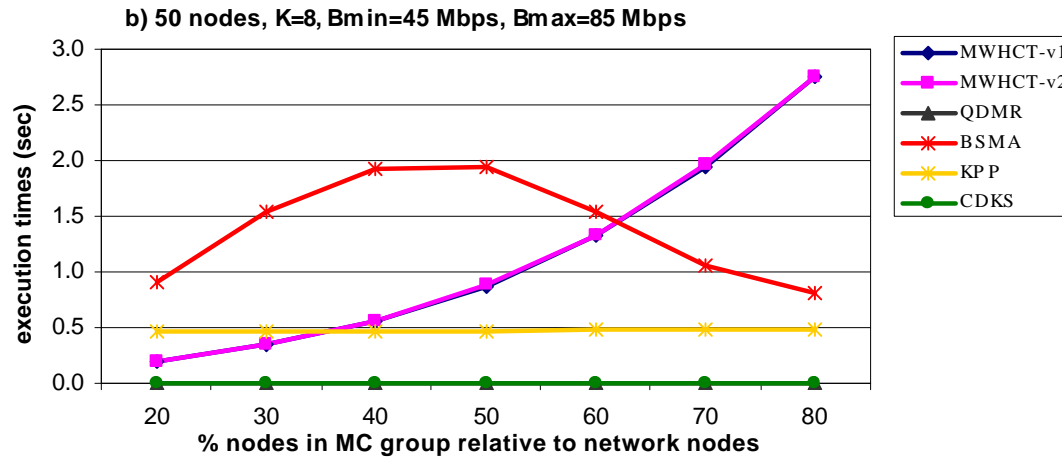

Max Hop  
Count 15

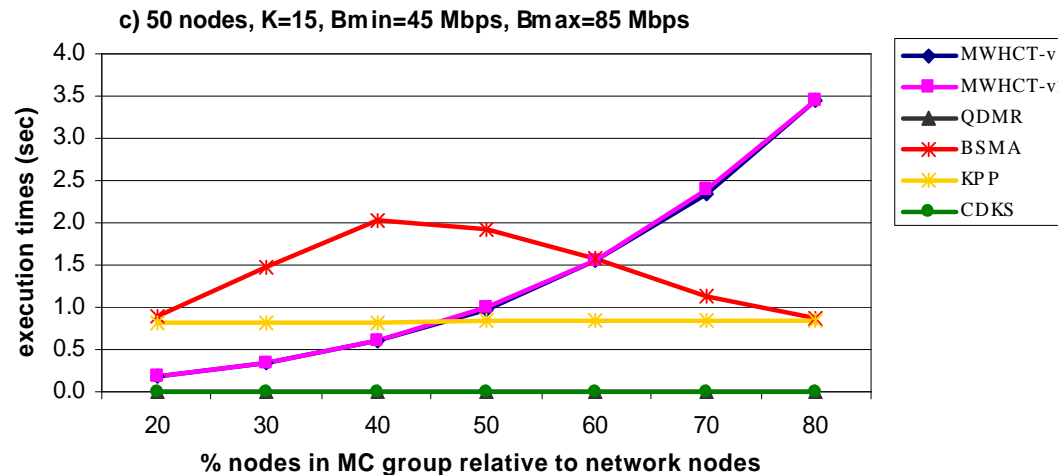



# 100 node network, min branch bandwidth 45 Mbps, max 85 Mbps

Max Hop  
Count 8

a) 100 nodes, K=8, Bmin=45 Mbps, Bmax=85 Mbps

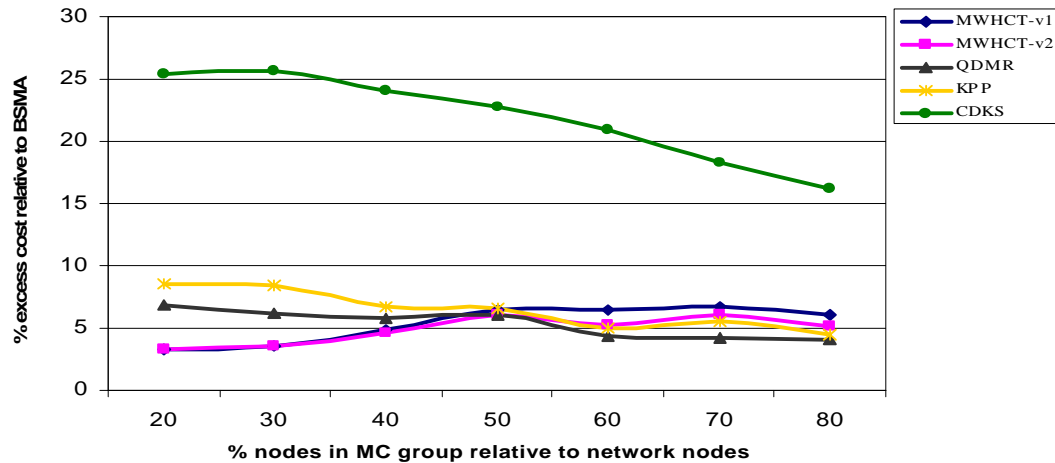

Max Hop  
Count 15

b) 100 nodes, K=15, Bmin=45 Mbps, Bmax=85 Mbps

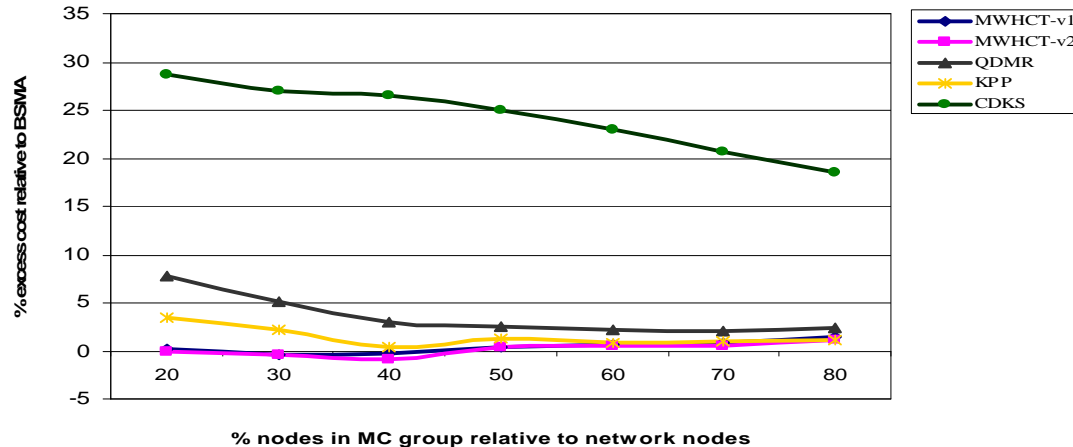



# Execution time comparison for the previous scenario

Max Hop  
Count 8

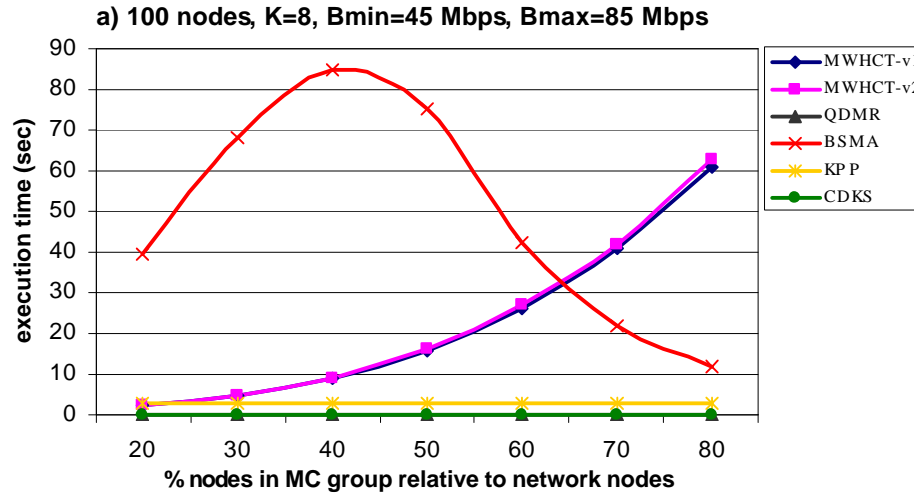

Max Hop  
Count 15

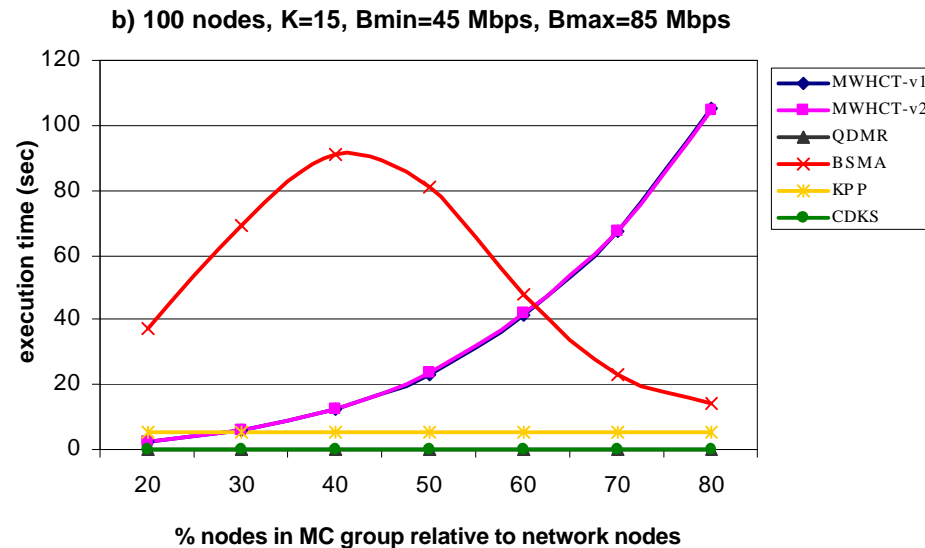



# Network Dimensioning Results: Experimental Set-up

---

---

- **Network topologies**
  - Waxman, pure random models [Zegura et al]
  - Up to 300 nodes, edge nodes 40-60%
  - Also on realistic topologies (MCI, vBNS)
- **Network load profiles:**
  - Aggregation of random Service Level Specifications
  - Load based on a percentage of the total first hop capacity
  - Medium load
    - SLSs aggregated to 40% of the total first hop capacity
  - High load
    - SLSs aggregated to 70% of the total first hop capacity



# Maximum and mean link load utilisation

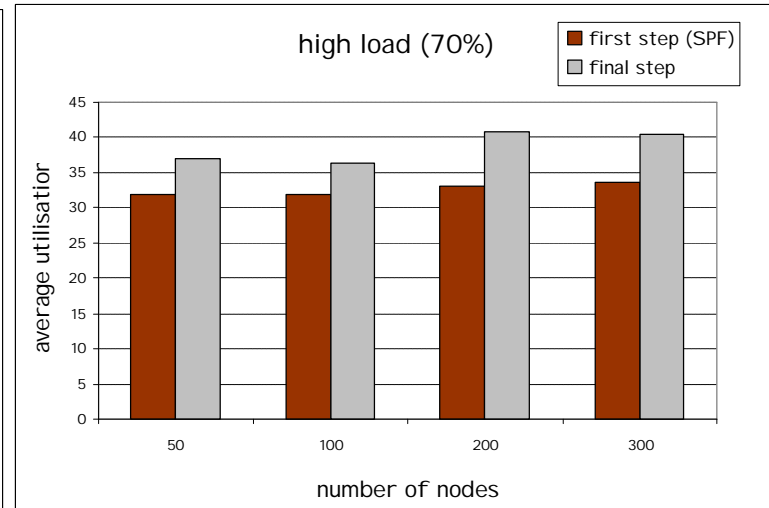
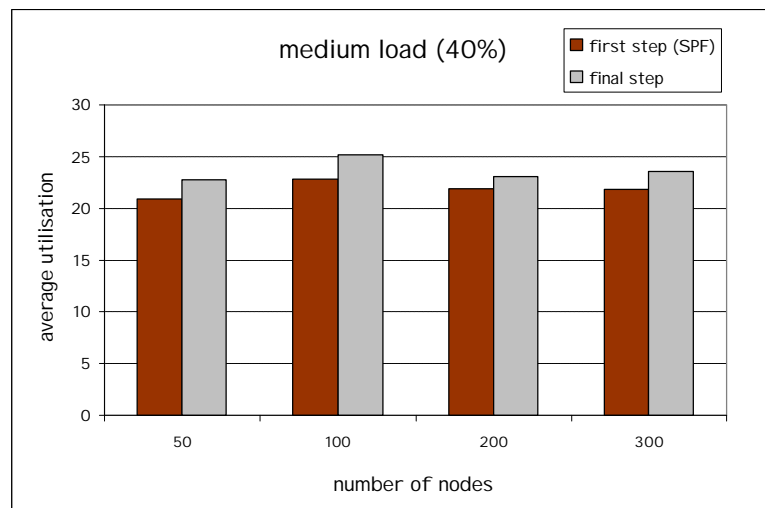
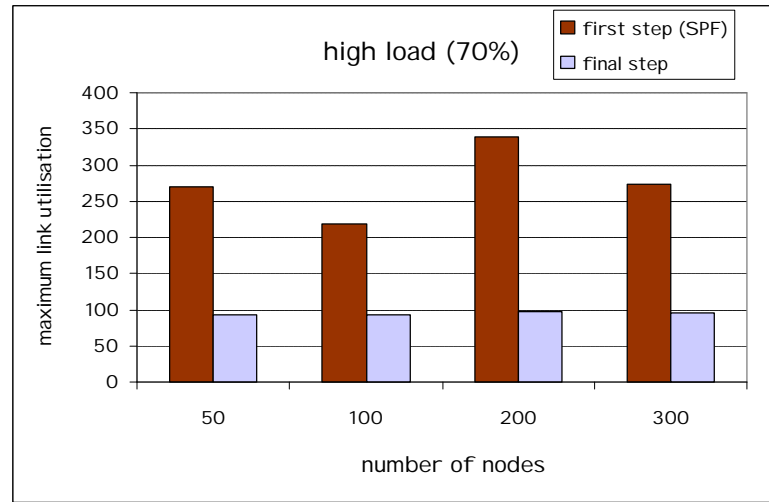
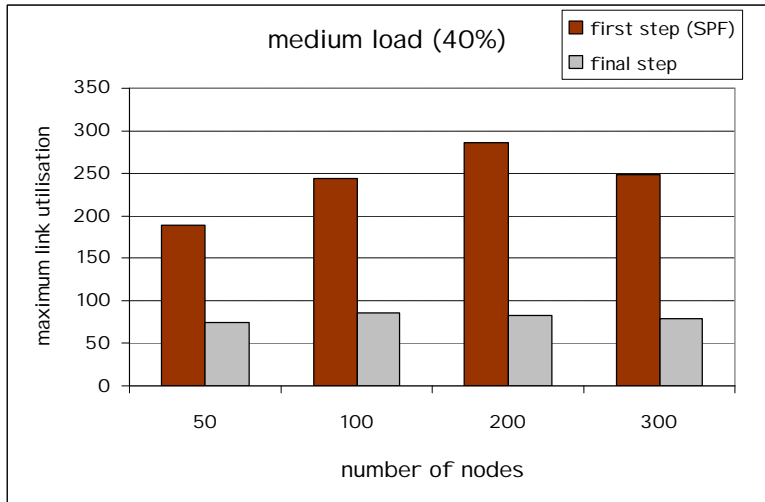



# Standard Deviation Link Load and Execution Time

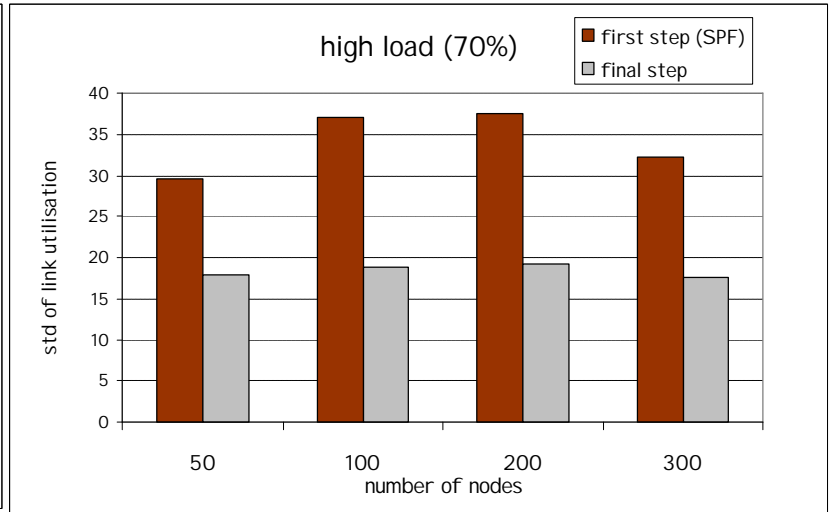
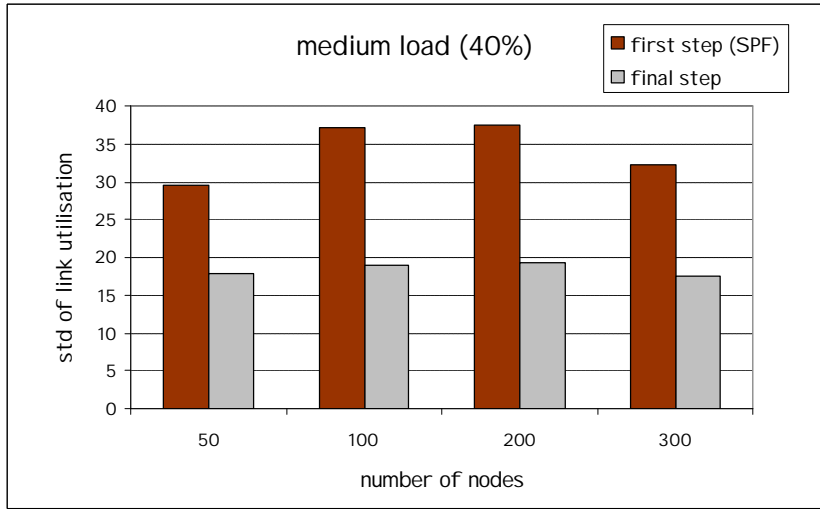

## Execution Time (seconds)

Nodes	Medium load	High load
10	0.055	0.061
50	9.761	10.164
100	123.989	302.079
200	529.532	1002.245
300	981.175	1541.937



# Dynamic Resource Management (DRsM) in TEQUILA

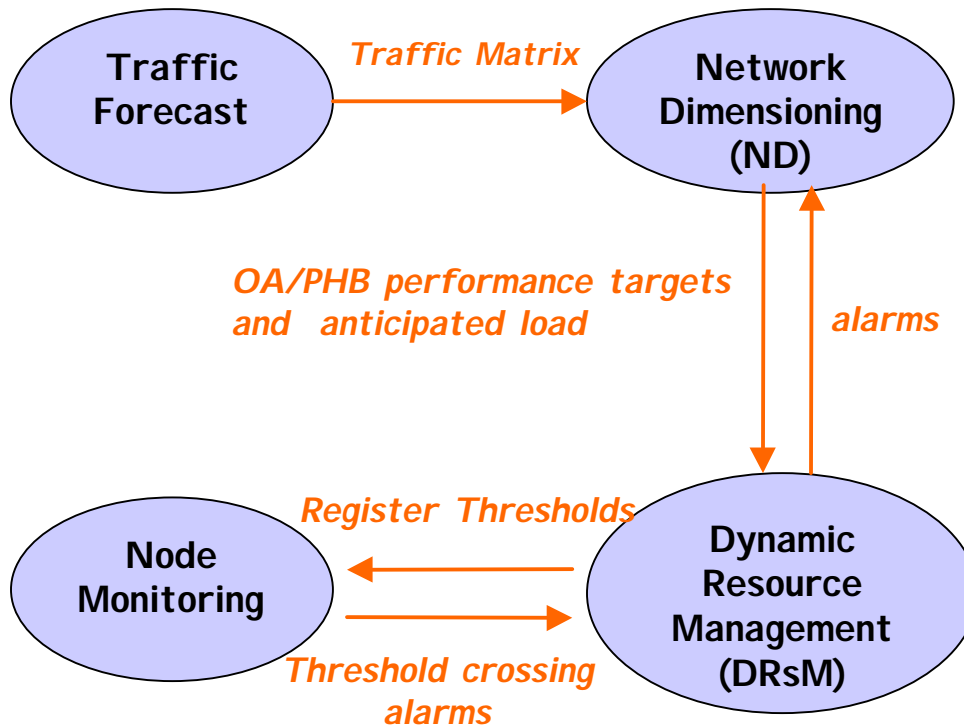

## Network Dimensioning

- centralised component
- maps traffic requirements on physical resources based on predicted traffic demand

## Dynamic Resource Management

- distributed component at every router
- refines the decisions taken by ND
- utilises actual network state and load information
- operates during a RPC

- Tracks the utilisation of each PHB by registering upper and lower thresholds to the node monitoring component
- Ensures allocated bandwidth to each PHB is in accordance to the required bandwidth

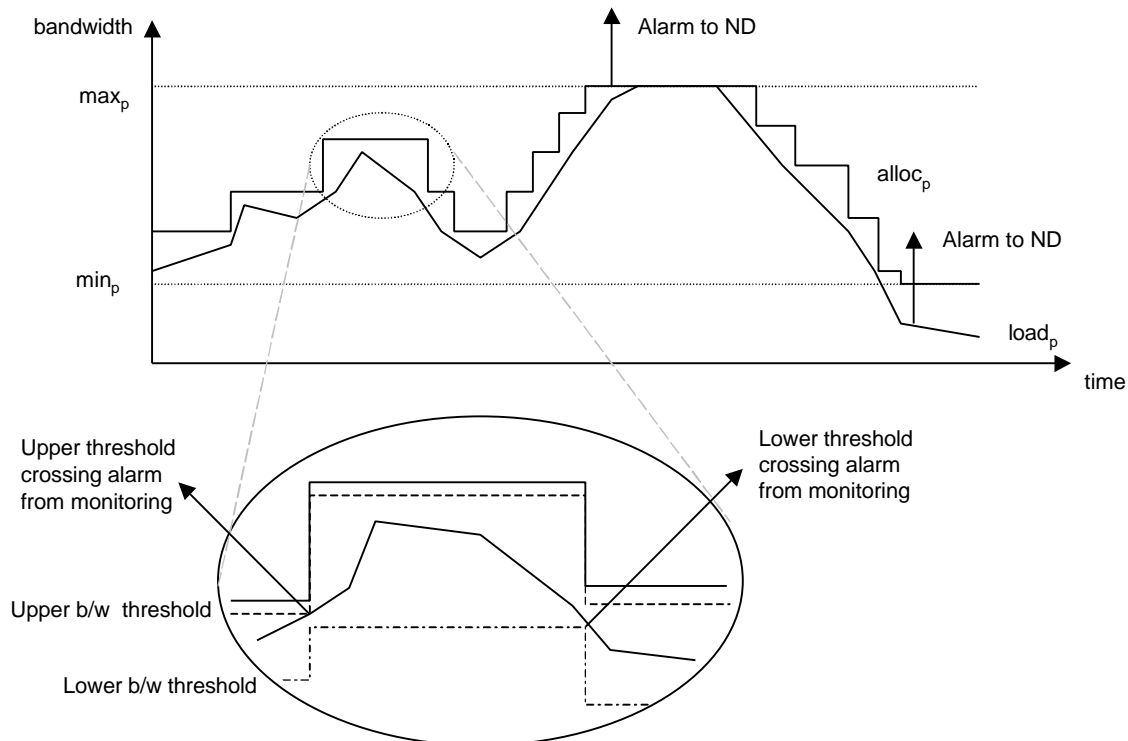



## DRsM Algorithm (cont'd)

---

- **Calculates required bw when a threshold is crossed**
  - Increase or decrease by an absolute value
  - Increase or decrease by a relative value
  - Predicted value for the next time interval is based on historical data
- **Calculates upper and lower threshold values**
  - Increase or decrease by an absolute, relative or extrapolated value with respect to current load
- **Bandwidth allocation among multiple PHBs**
  - Non-congestion (sum of required Bw < Link Capacity) : Distributes the remaining bandwidth equally or proportionally
  - Congestion (sum of required Bw > Link Capacity): Allocates a minimum share to each PHB (calculated by ND) and distributes the remaining bandwidth equally or proportionally



# DRsM Evaluation on Single Hop: Traffic Scenarios

a) Simple Scenario

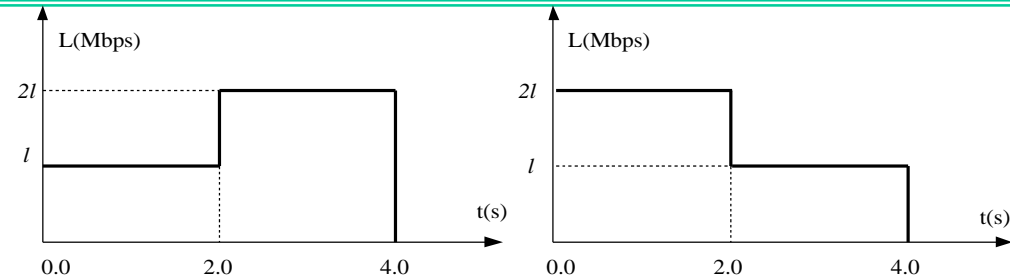

b) Complex Scenario

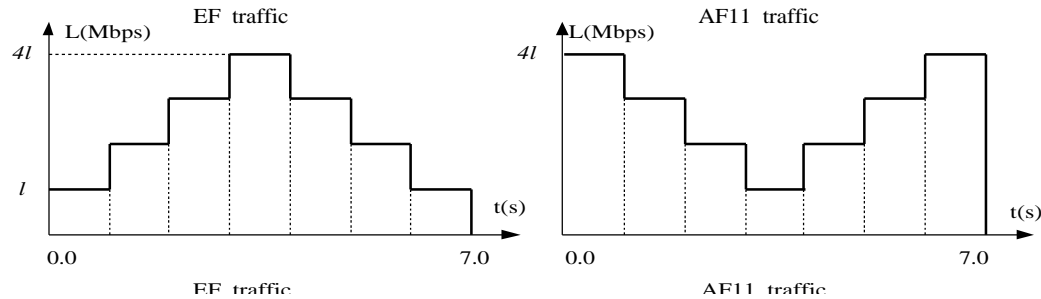

c) Random VBR Scenario

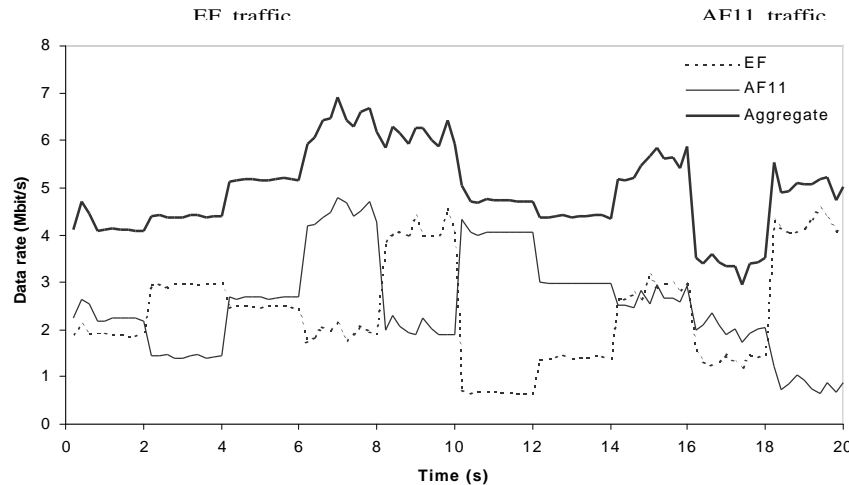



# Example DRsM Real-time Activity: Complex Traffic, EF Queue

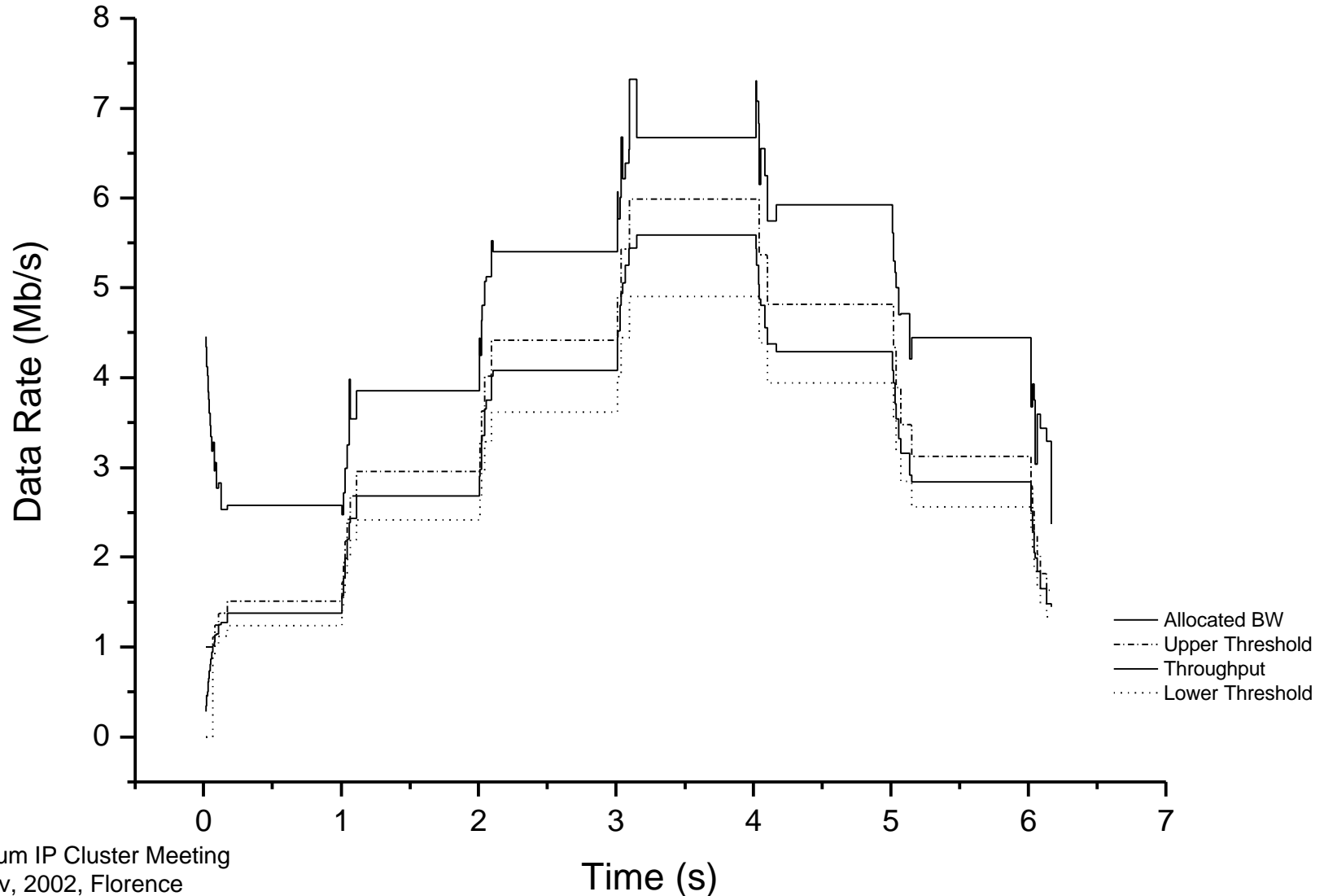



# DRsM vs Static Bandwidth Allocation Complex Traffic Scenario - VBR

Comarison of DRsM vs Static Bandwidth Allocation  
Complex Traffic - VBR

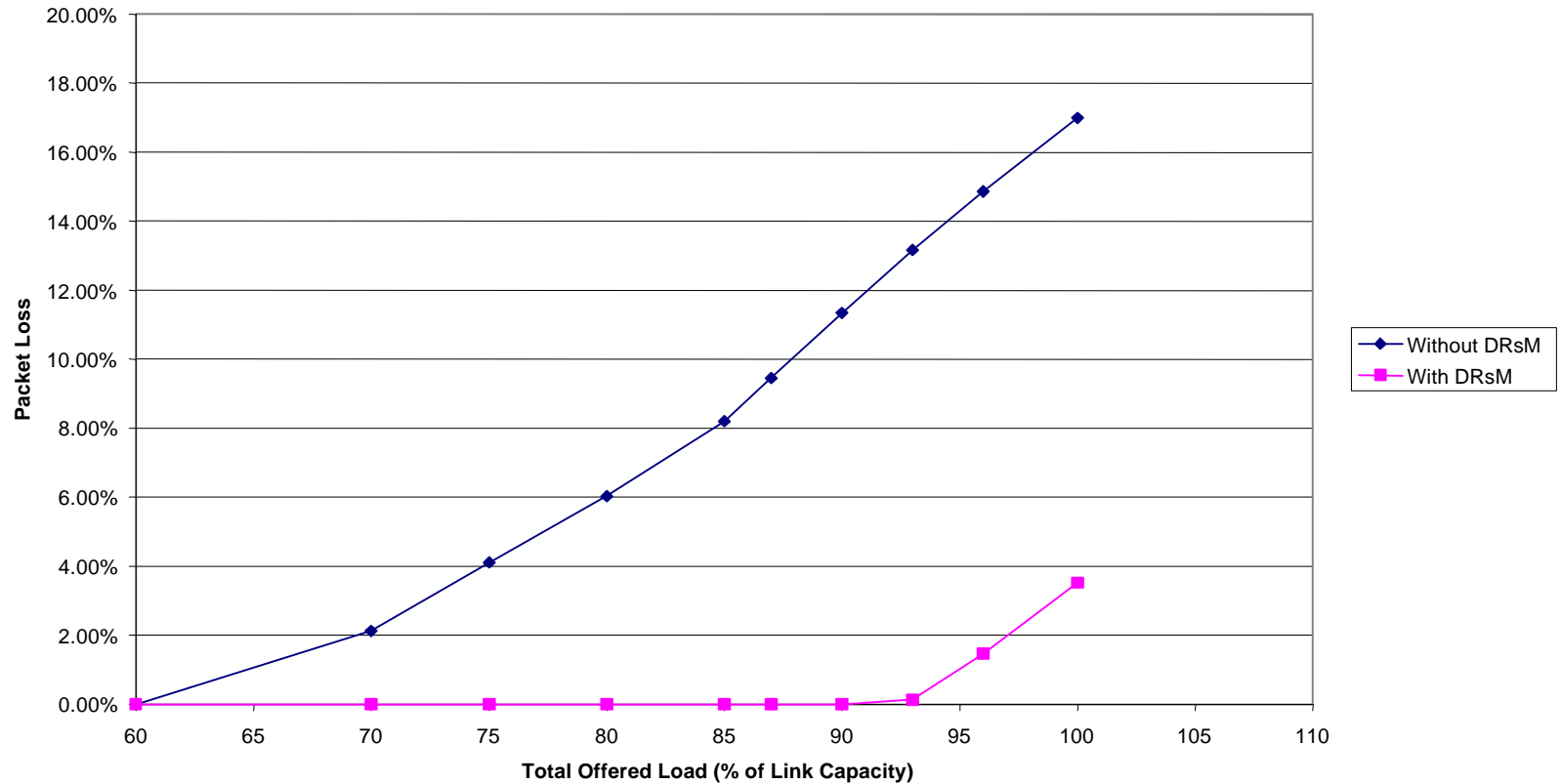



# DRsM vs Static Bandwidth Allocation Random VBR Scenario

Comparison of DRsM vs Static Bandwidth Allocation  
Random VBR

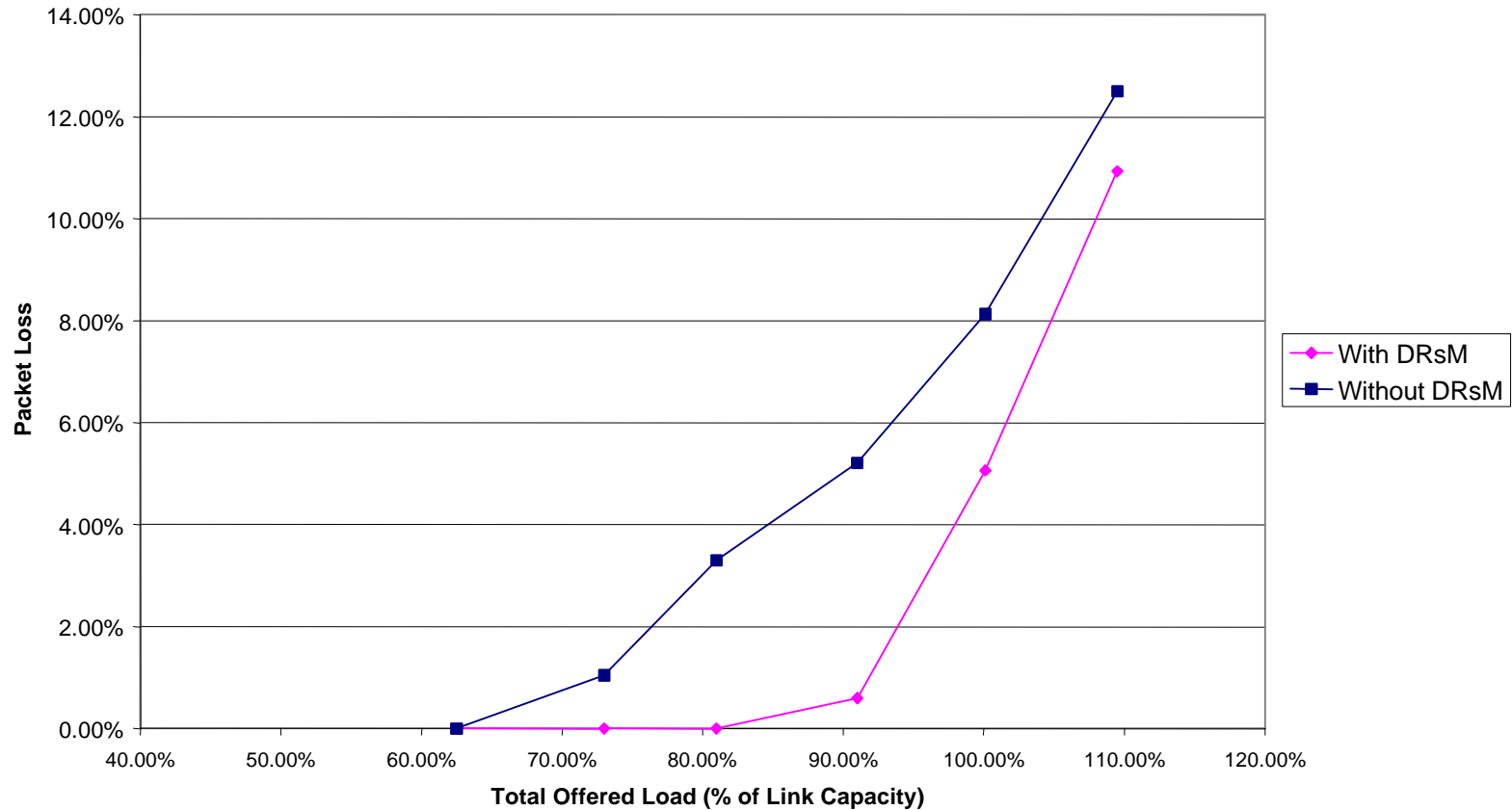



# Summary of Improvement with DRsM

Loss Improvement for DRsM over Static Bandwidth Allocation

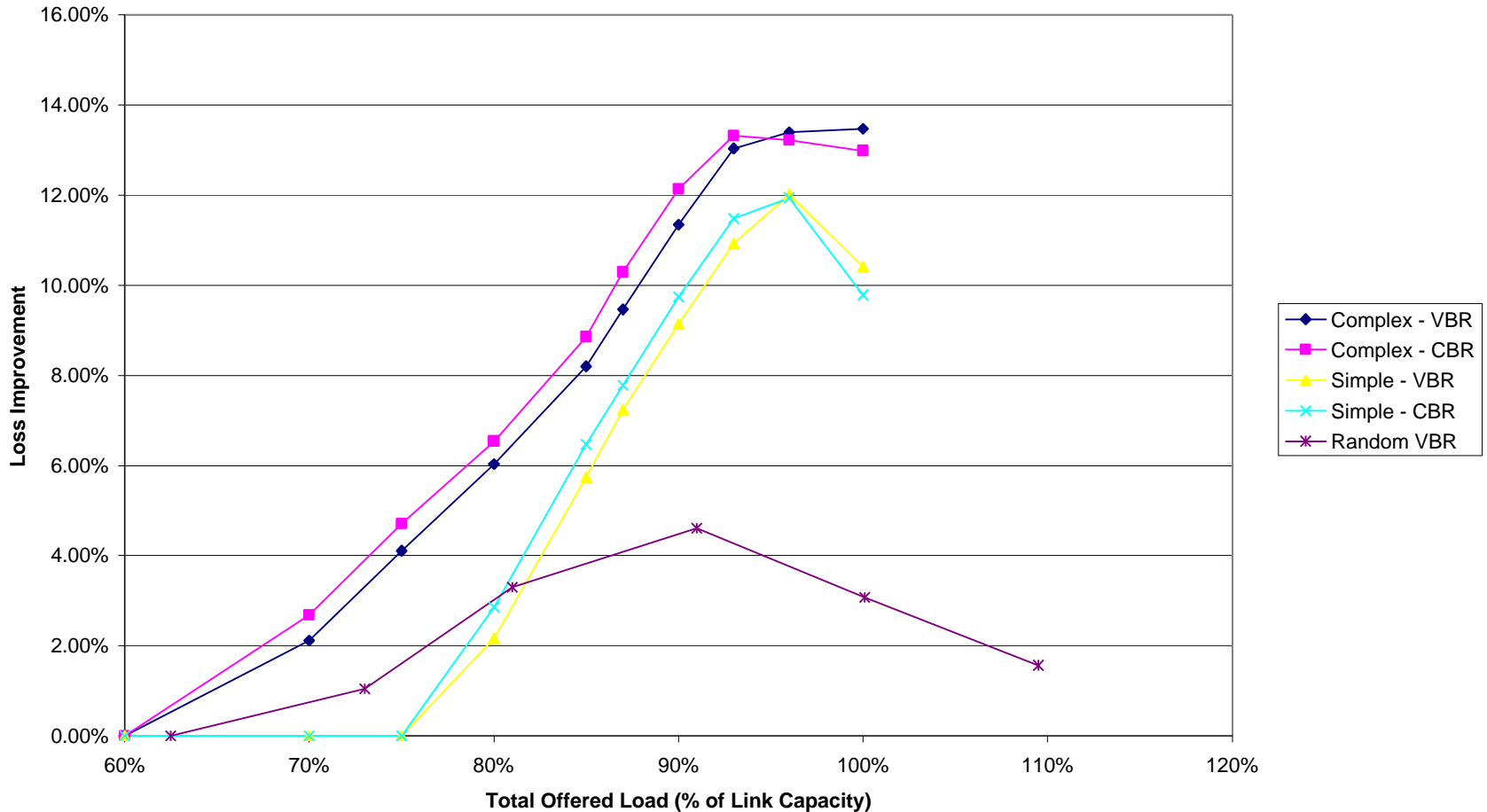



# Conclusions

---

- **Our MWHCT constrained Steiner tree algorithm betters BSMA for small to medium size hose destination nodes (approx. < 60% of total edge nodes) with much lower execution time**
- **Our ND Gradient Projection algorithm gives excellent results for maximum link load, i.e. well < 100%, while shortest path utilisations are > 300%, and achieves very small end-to-end delay**
- **Our ND algorithm scales well for big networks in terms of execution time which is < 20 mins for networks of 300 nodes**
- **Our DRsM algorithm improves significantly packet loss in times of congestion, providing up to 13% of link capacity improvement**
- **Our ND system can be tuned in terms of operational requirements, being policy-driven**
- **Our DRsM system can be fully implemented as a set of policies for the router, achieving programmability by being able to operate in routers with no more than forwarding, monitoring and policy functionality**



---

# **TEQUILA Service Management System Results**

**Eleni Mykoniati**  
**Telecommunications Laboratory**  
**National Technical University of Athens, Greece**  
**mykel@telecom.ntua.gr**

**TEQUILA Consortium**



# Detailed Architectural View

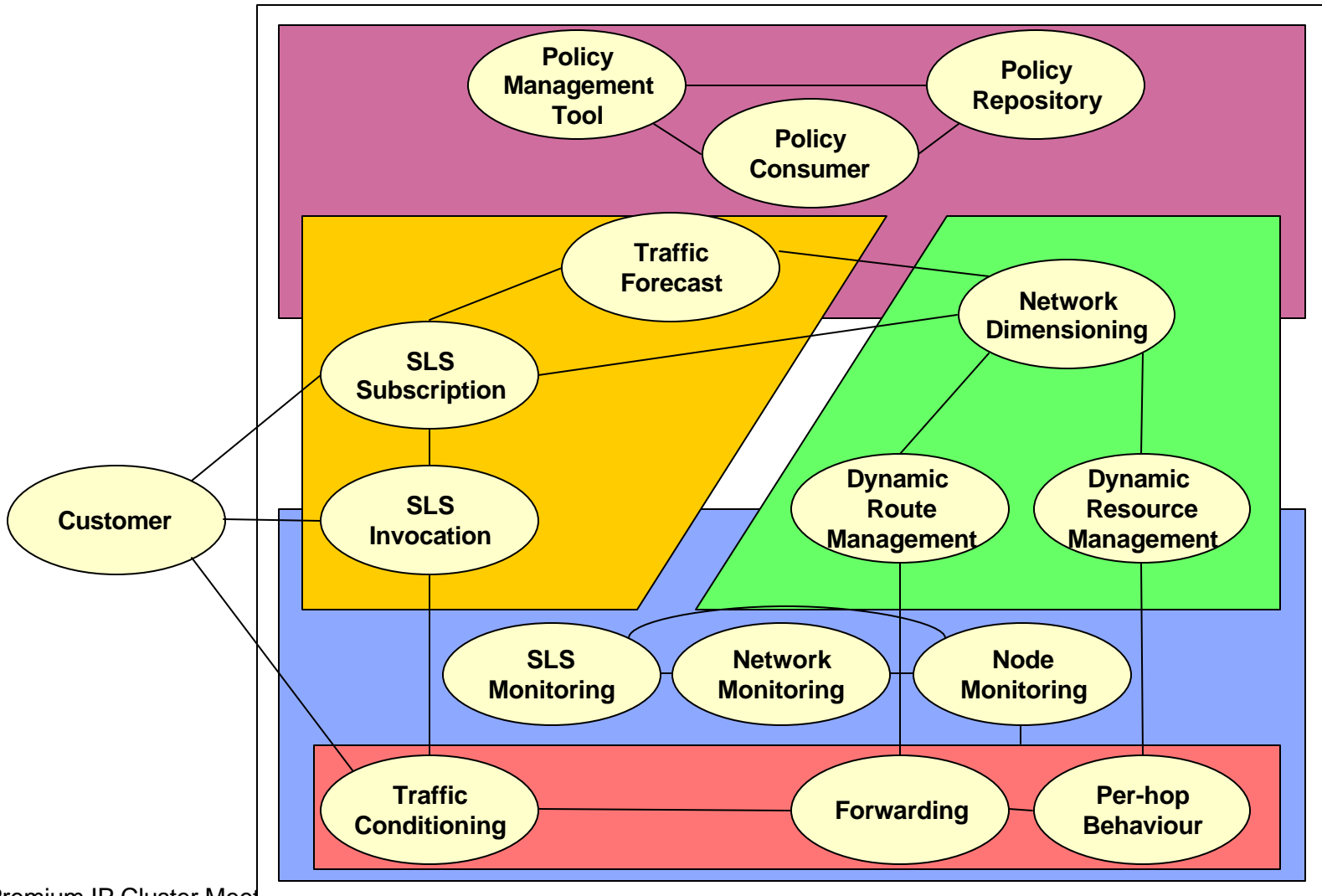



# Focus on Service Management

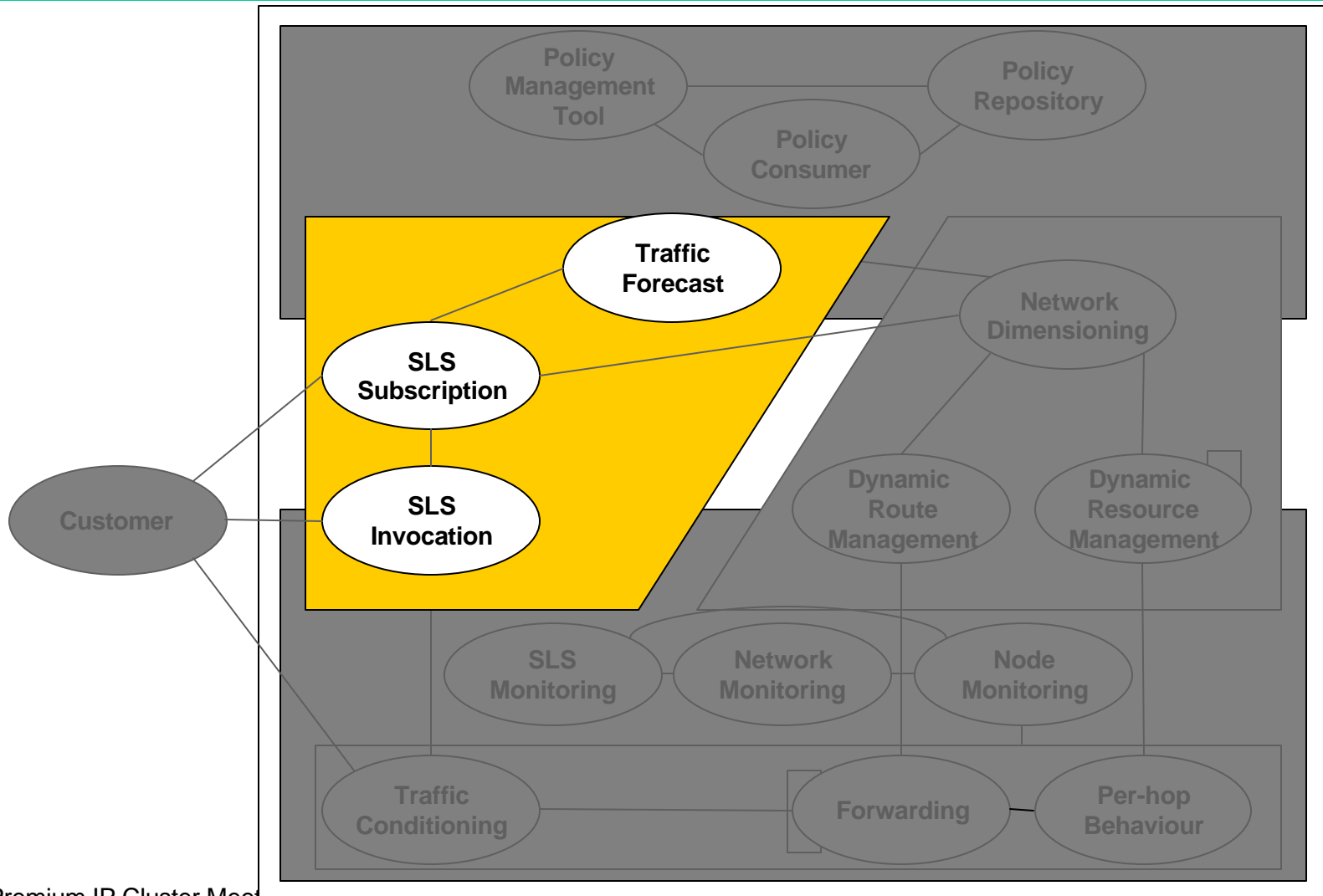



# Principles

---

- **Comprehensive description of SLSs – to agree on QoS**
  - The TEQUILA SLS template proposed in IETF
- **A layered approach to bind services to resources**
  - Services → QoS Classes → PHBs
- **Two epochs in service requests: subscriptions and invocations**
  - Customers **subscribe** to gain ‘right to invoke services’; The TEQUILA SSS template represents a service subscription
  - Users **invoke** services, **explicitly** (protocol based e.g. RSVP) or **implicitly** (just sending data e.g. VPN service)



# Resource Availability Estimates

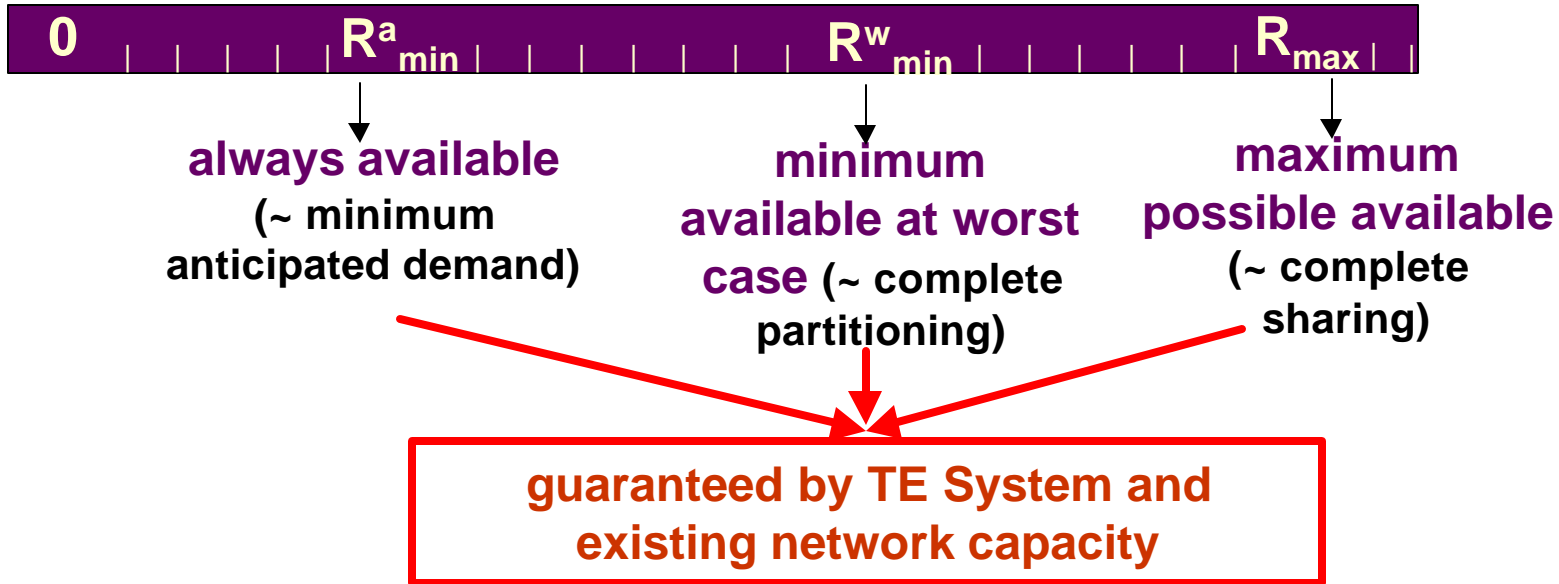

*subscription and invocation logic rely on availability estimates, from their own perspectives*  
*no hard reservations per TT*



# Two-Level Admission Control

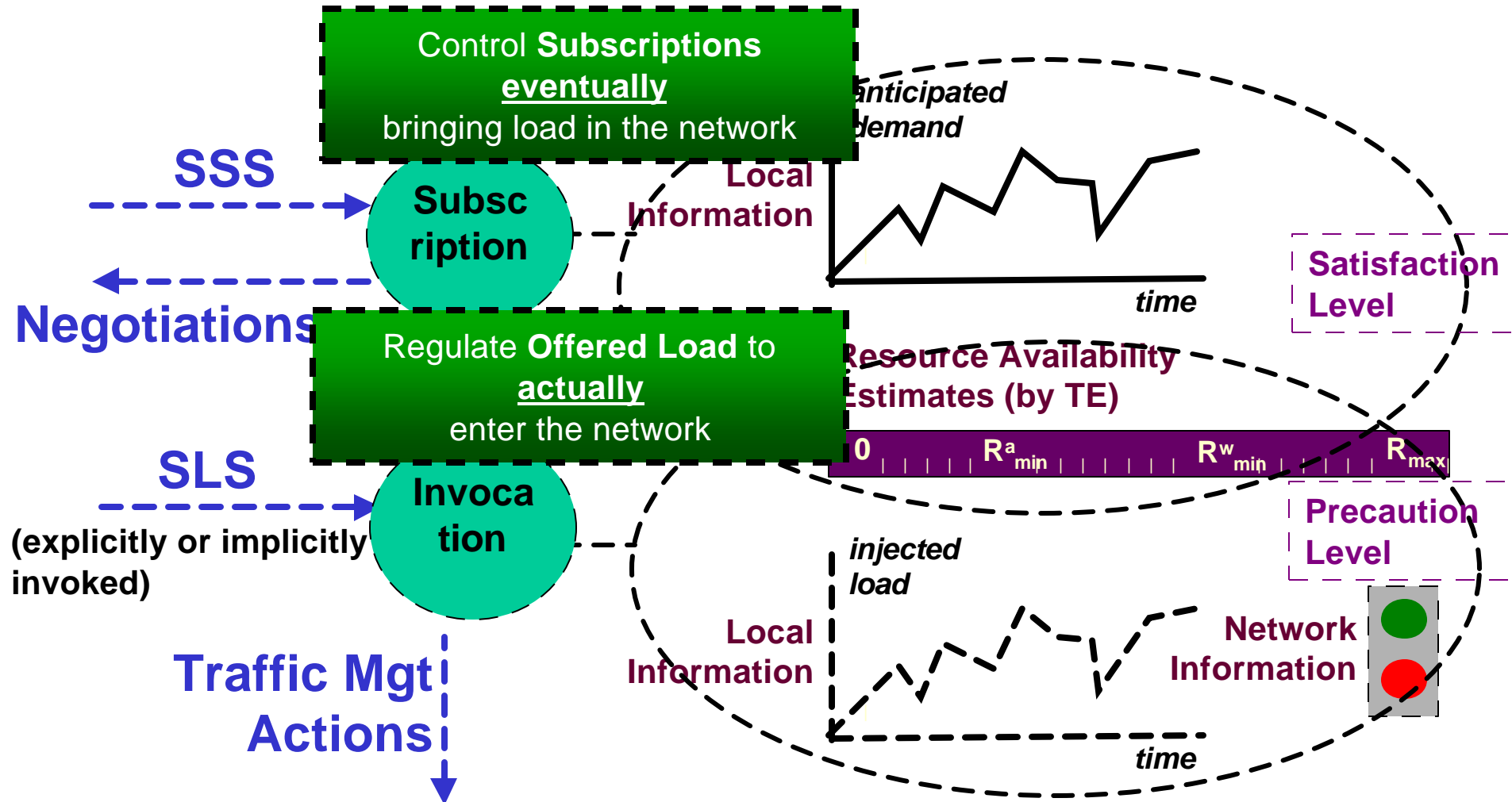



# Satisfaction Level Precaution Level

## Satisfaction Level

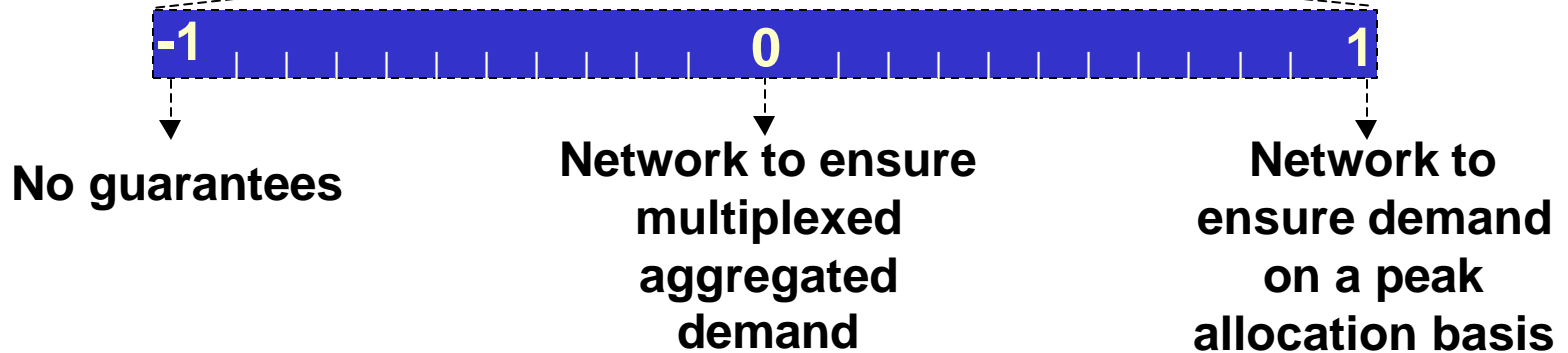

## Precaution Level

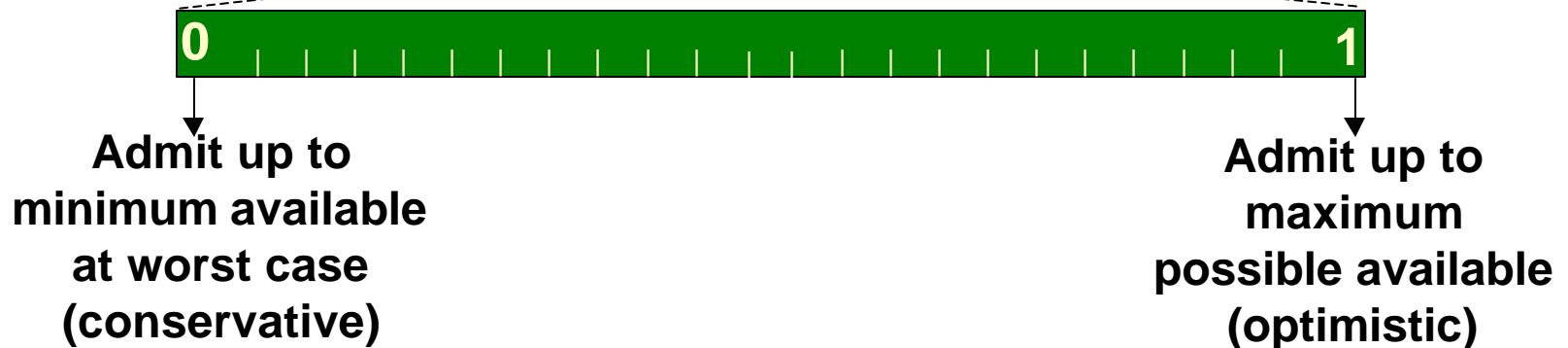



# Testing Components

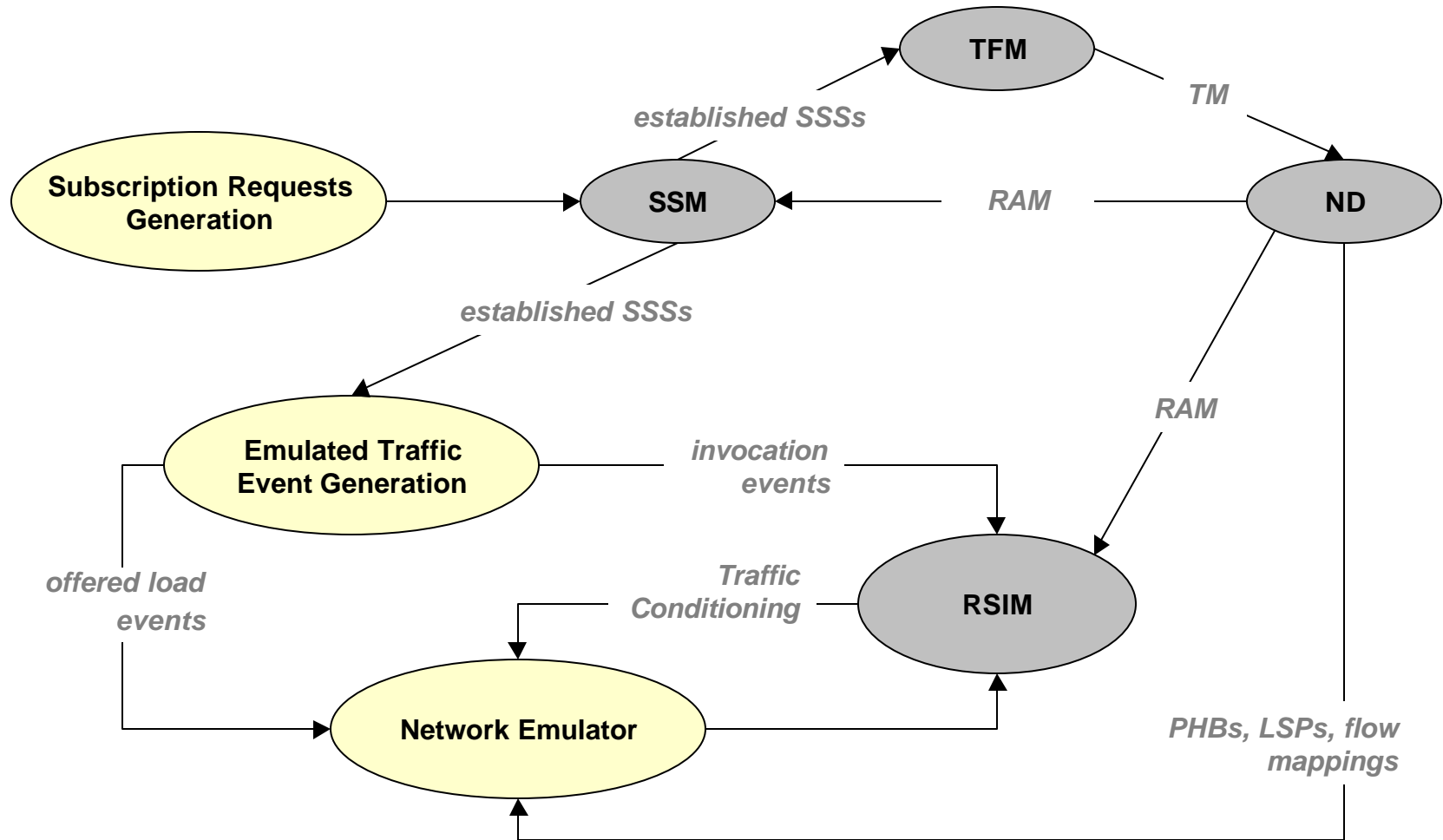



# Traffic Patterns Settings

Service Types		OA		Subscription Generation				Traffic Demand Generation													
				Subscriptions Number		Percentage		Downstream Rate		Upstream Rate		Inflation Factor	Invocation					Load			
													Max Simultaneous Users	Distribution	Mean Holding Time	Mean Interarrival Time	Variance	Distribution	Mean OFF Time	Mean ON Time	Variance
min	max	min	max																		
Permanent VPN	EF	455	20%	1000	2000	1000	2000								Pareto	30		N/A			
Flexible VPN	AF3		25%	500	500	500	500		10	Gen Exp	100		5	Constant							
Flexible Peer-to-Peer	AF1		15%	500	1000	500	1000		8	Gen Exp	1200		5	Pareto	30			N/A			
On-Demand Peer-to-Peer	AF1		30%	64	64	64	64			Gen Exp	240	600	5	Gen Exp	15	45	8				



# Network Topology

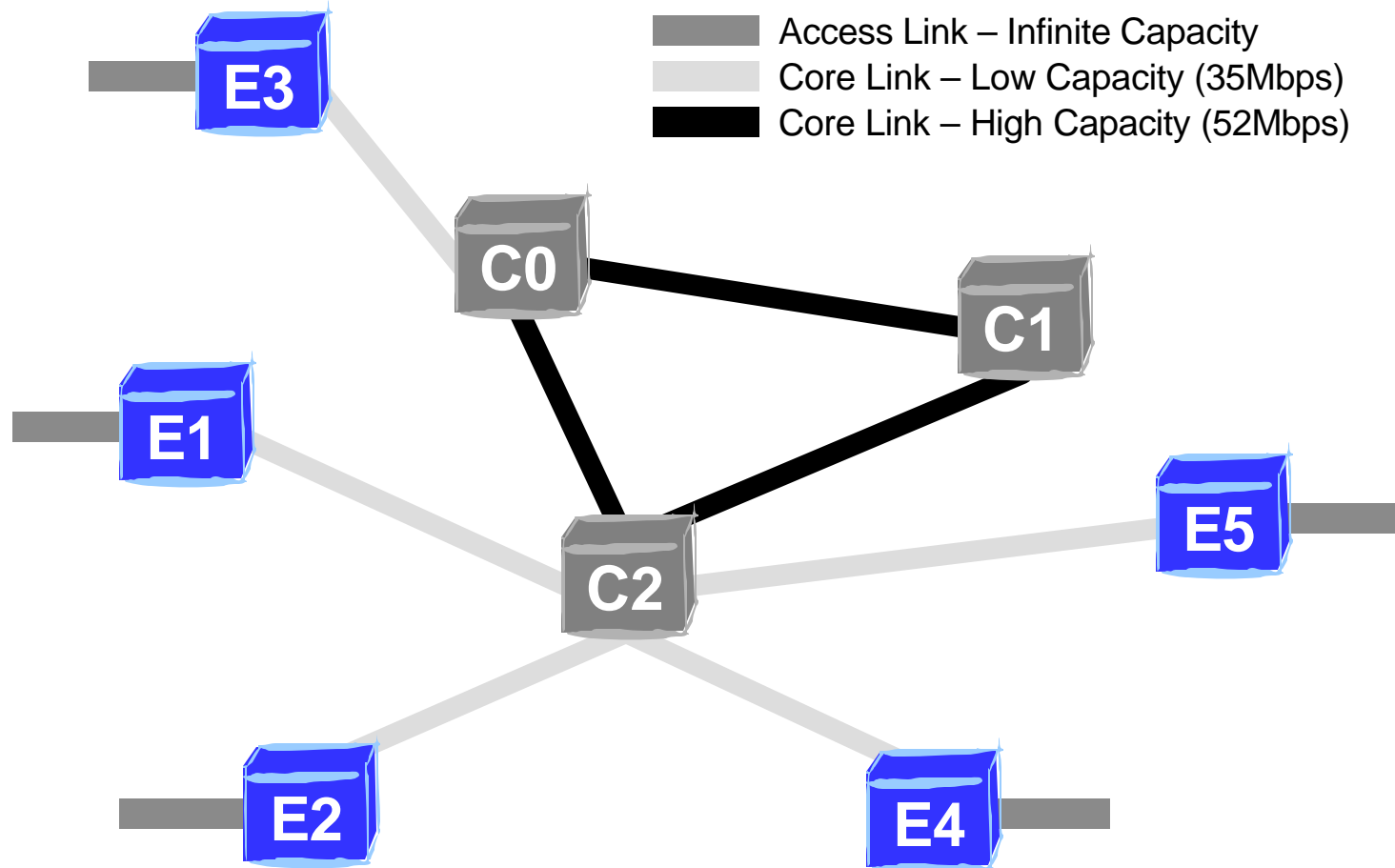



# Cost/Benefit Tests

## RSIM

- **Uncontrolled variables**
  - **Accuracy of RAM with respect to actual user behavior:**
    - Deviation in terms of intensity overall
    - Deviation in terms of intensity between different QoS-classes
- **Metrics to assess the performance**
  - **Benefit**
    - The proportion of green traffic delivered with RSIM over the green traffic delivered without RSIM
  - **Cost**
    - The accepted over requested invocations ratio (penalty at call level)
    - The injected throughput over offered throughput ratio (penalty at packet level)



# Test Cases

		Low Traffic Demand Intensity			High Traffic Demand Intensity		
		EF	AF1	AF3	EF	AF1	AF3
symmetric	<b>Test Case R-1</b>				<b>Test Case R-3</b>		
	Overall Load over Capacity	<b>0,6</b>			Overall Load over Capacity	<b>1,25</b>	
	Inflation over R(aw)				Inflation over R(aw)	<b>0,4</b>	
	Weight to Load	<b>1</b>	<b>1</b>	<b>1</b>	Weight to Load	<b>1</b>	<b>1</b>
asymmetric	<b>Test Case R-2</b>				<b>Test Case R-4</b>		
	Overall Load over Capacity	<b>0,7</b>			Overall Load over Capacity	<b>1,5</b>	
	Inflation over R(aw)	<b>0,1</b>	<b>0,1</b>		Inflation over R(aw)	<b>0,5</b>	
	Weight to Load			<b>1</b>	Weight to Load	<b>1</b>	<b>2</b>

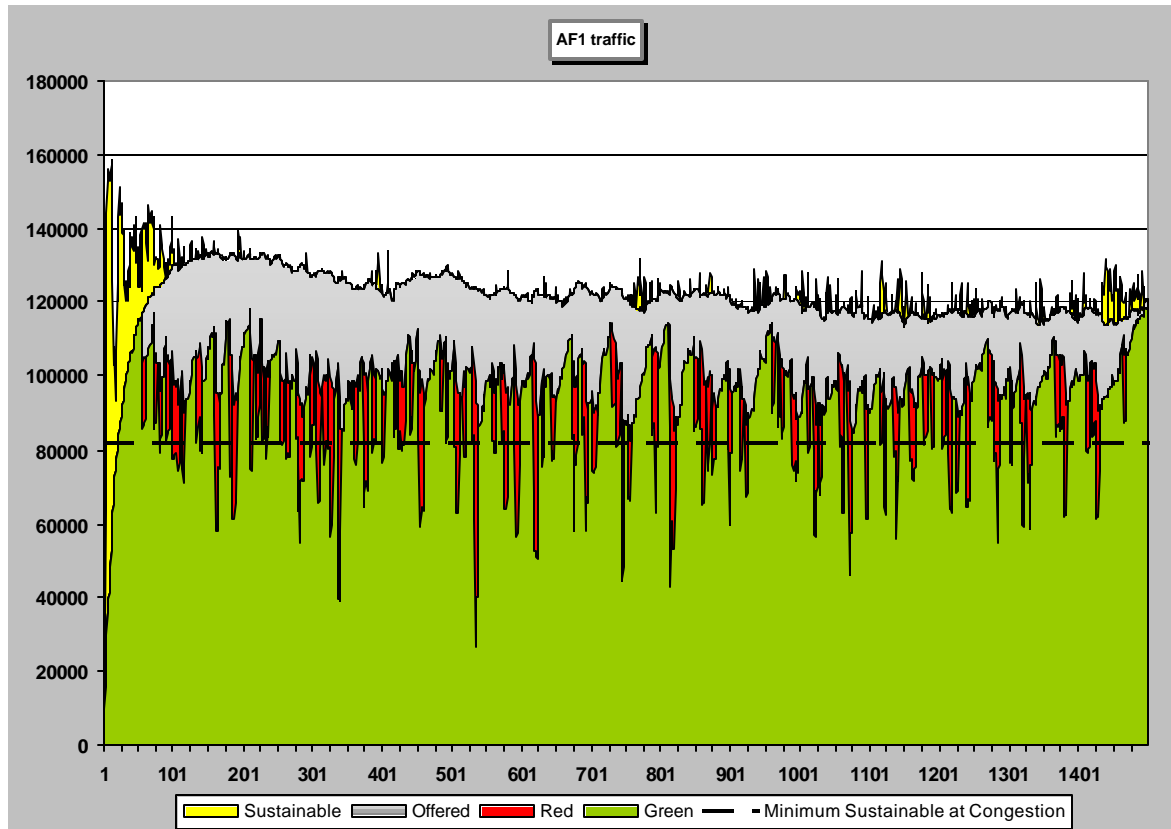



# High Asymmetric Traffic Demand Test Results

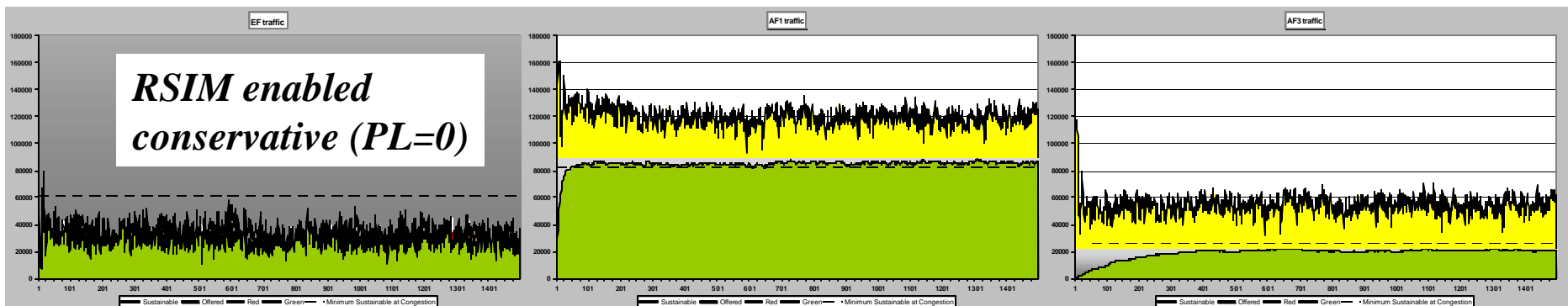
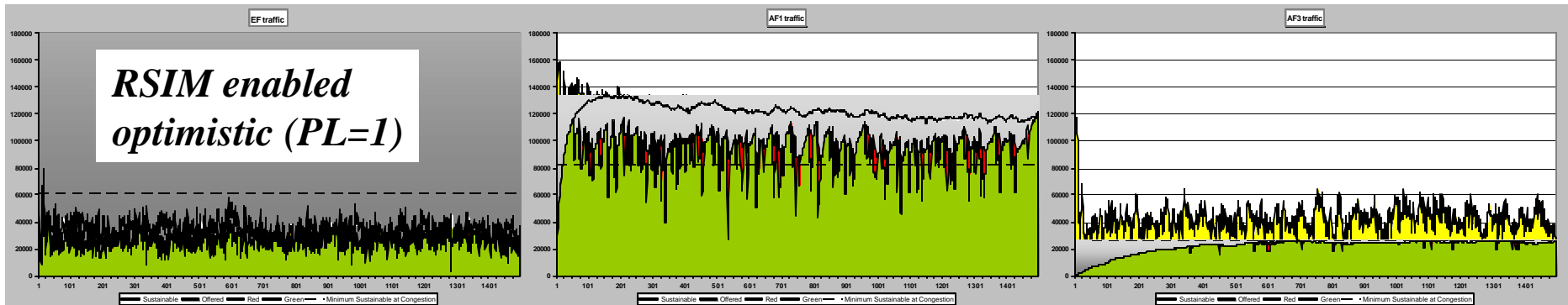
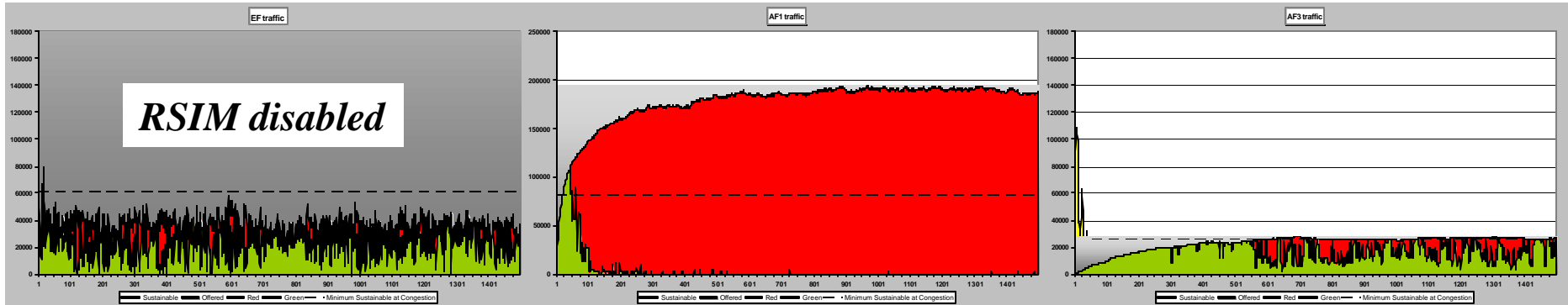



# High Asymmetric Traffic Demand Test Comparative Results

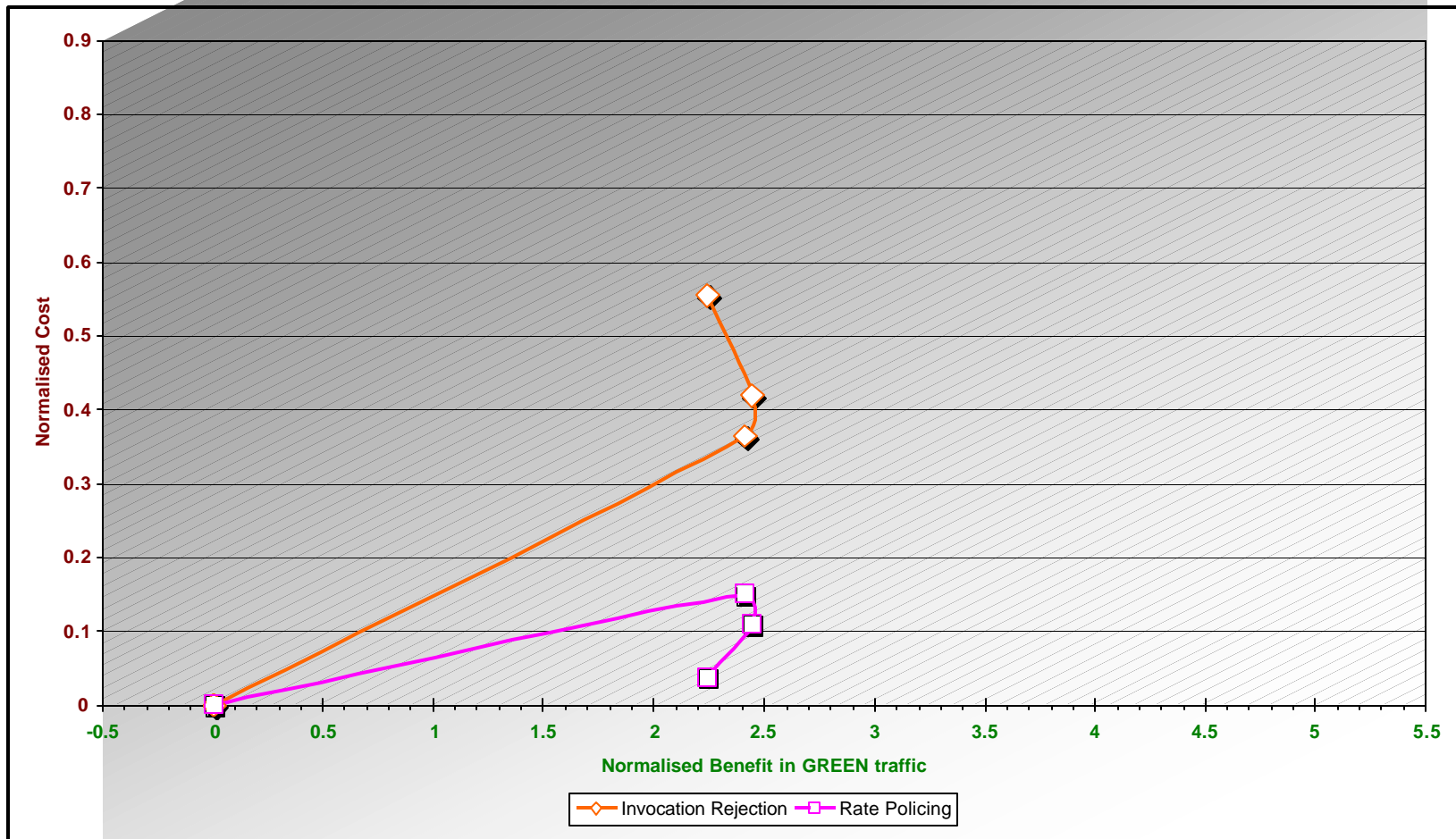



# Cost/Benefit Tests

## SSM

---

---

- **Uncontrolled variables**
  - **Accuracy of RAM with respect to actual user behavior:**
    - Deviation in terms of intensity overall
    - Deviation in terms of intensity between different QoS-classes
  - **Validity of source models used for:**
    - Implied demand derivation per subscription
    - Implied demand aggregation per Traffic Trunk
- **Metrics to assess the performance**
  - **Benefit is assessed based on the effect on RSIM benefit**
  - **Cost is assessed based on the effect on RSIM cost**



# Test Case

- **Traffic patterns are the same as in high asymmetric traffic demand RSIM test case**
- **Subscription requests are negotiated with SSM configured to operate with:**
  - **Satisfaction Level = -1**  
(no guarantees – identical with plain RSIM test case)
  - **Satisfaction Level = 0.1/0.3/0.6**  
(guarantees at several levels of multiplexing)
  - **Satisfaction Level = 1**  
(guarantees on peak allocation)
- **The resulted established subscriptions are used to setup the experiment**
- **SIM operates with Precaution Level = 1 (optimistic)**
- **The delta in RSIM benefit and cost is assessed across the various settings of Satisfaction Level**



# SSM Test Results

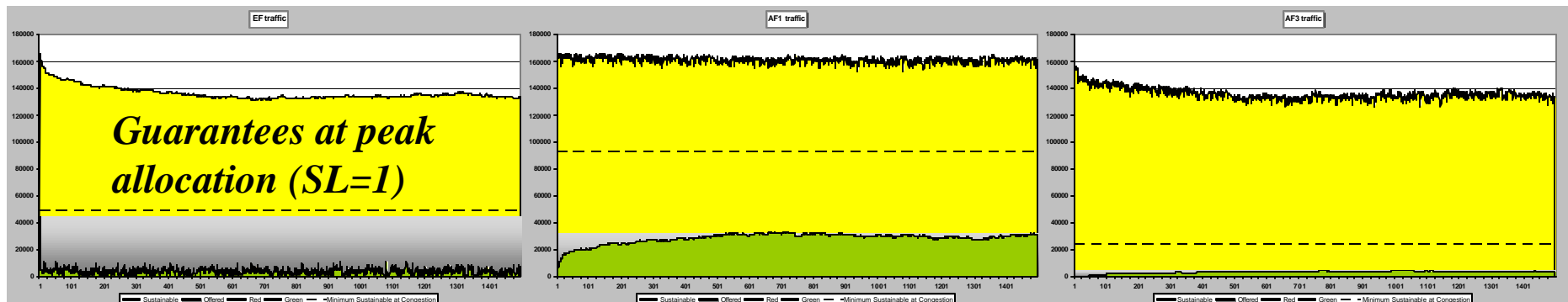
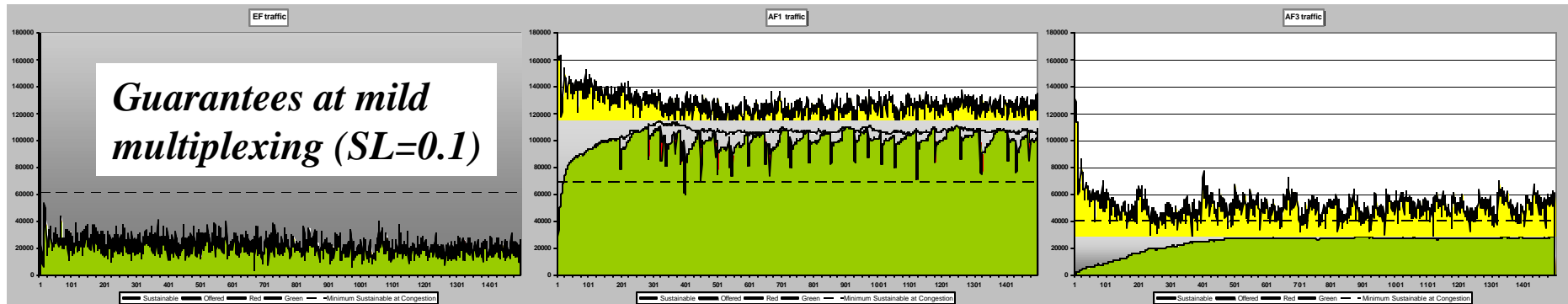
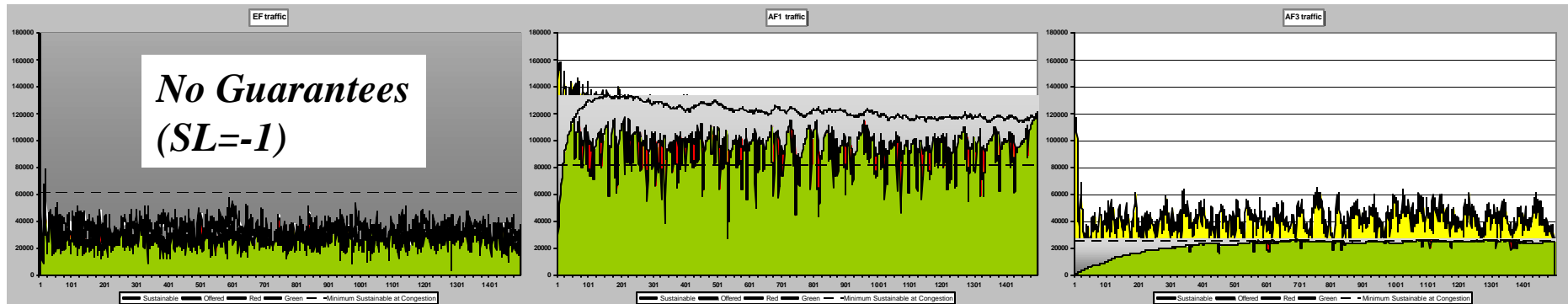



# Conclusions

---

---

- **Usability**
  - The system operation can be tuned at all three levels of control:  
(1) Subscription admission, (2) Invocation admission, (3) Rate admission
  - The resolution of the traditional admission control trade-off is left to policies
- **Cost/Benefit**
  - Dynamic invocation admission control logic:
    - Increases service satisfaction keeping the network utilisation high
    - Effectively resolves congestion with fairness network-wide
  - Subscription admission control logic
    - Enhances the ability of invocation admission control logic to increase service satisfaction
- **Scalability**
  - It scales for big numbers of SLSs (customers' population size)
  - It scales for big numbers of Traffic Trunks (network size)
  - The most time consuming function is SLS translation and validation



---

# UK Testbed: MPLS-TE Results

**Richard Egan**

**Hamid Asgari**

**Mark Irons**





# Presentation Outline

---

- **Tests Overview**
- **UK Testbed**
- **Results**
  - **Differentiated Service**
  - **Commercial Routers**
  - **Pipes/Hoses**
- **Summary of Key Results**



# Tests Overview

---

- **System Level Performance Tests**
- **Verify MPLS-TE**
- **Verify Monitoring (Maastricht)**
  - use Monitoring to gather data for MPLS-TE tests
- **TEQUILA Components deployed in testbed**
  - BSRGen
  - SLS Management (RSIM & Traffic Forecast)
  - Network Dimensioning
  - RtM, RsM
  - GAL/Cisco Routers
  - Monitoring

# TEQUILA UK Testbed

TRL  
Internal  
Network

## NTP Specific Ethernet Network

BRIDGE  
PC8734  
(SMB)

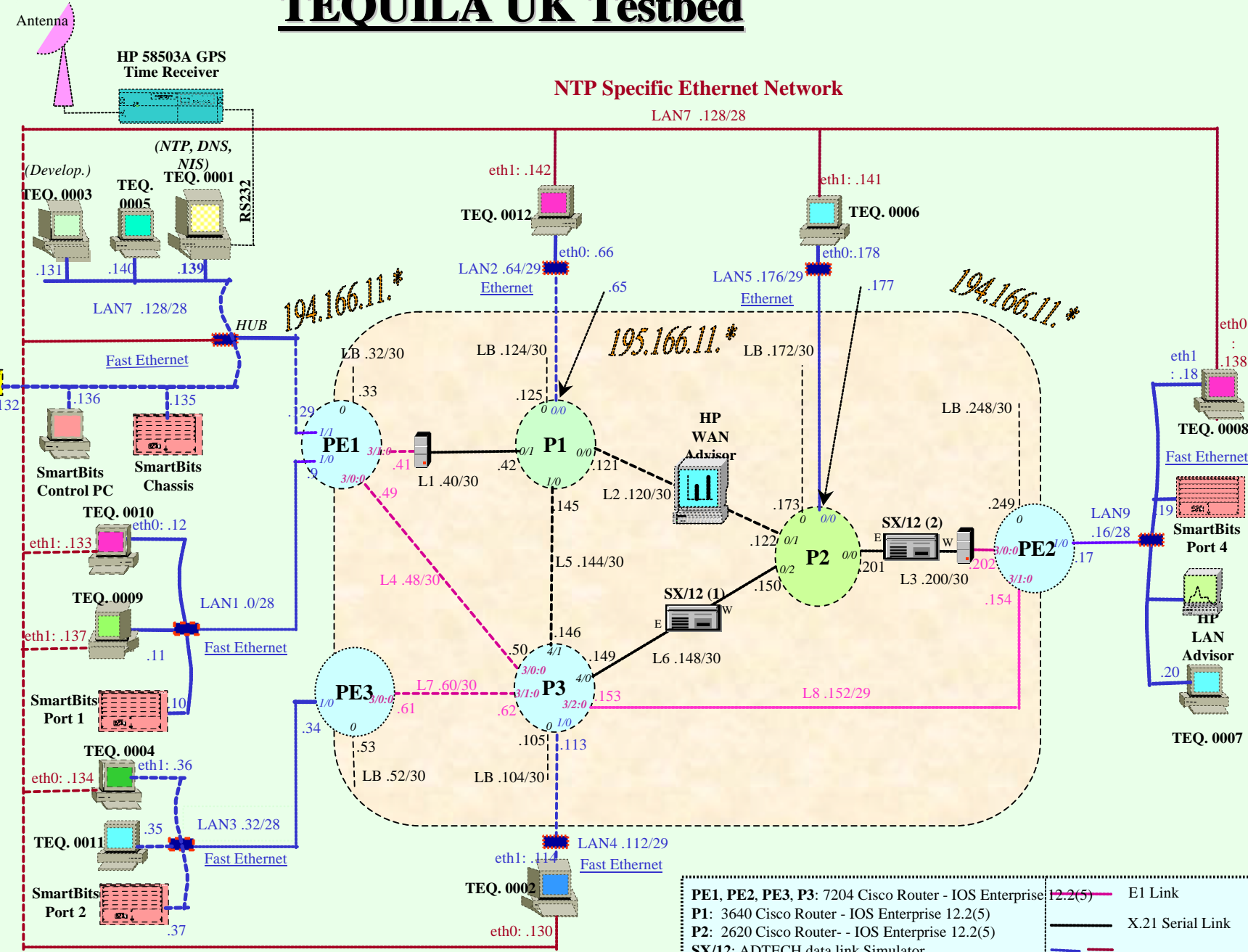

PE1, PE2, PE3, P3: 7204 Cisco Router - IOS Enterprise 12.2(5)  
 P1: 3640 Cisco Router - IOS Enterprise 12.2(5)  
 P2: 2620 Cisco Router - IOS Enterprise 12.2(5)  
 SX/12: ADTECH data link Simulator  
 HP WAN/LAN Advisor: WAN/LAN Protocol Analysers  
 HP 58503A: GPS Time & Frequency Reference Receiver

— E1 Link  
 — X.21 Serial Link



# Test Objective

---

- **Verify TEQUILA system's ability to create a Differentiated Services network**
  - Qualitative
  - Extrapolate Customer Demand for Resource Provisioning Cycle (RPC)
  - Quantitative (Delay Guarantees)
    - EF < 150ms
    - AF < 400ms

# Differentiated Service (Qualitative)

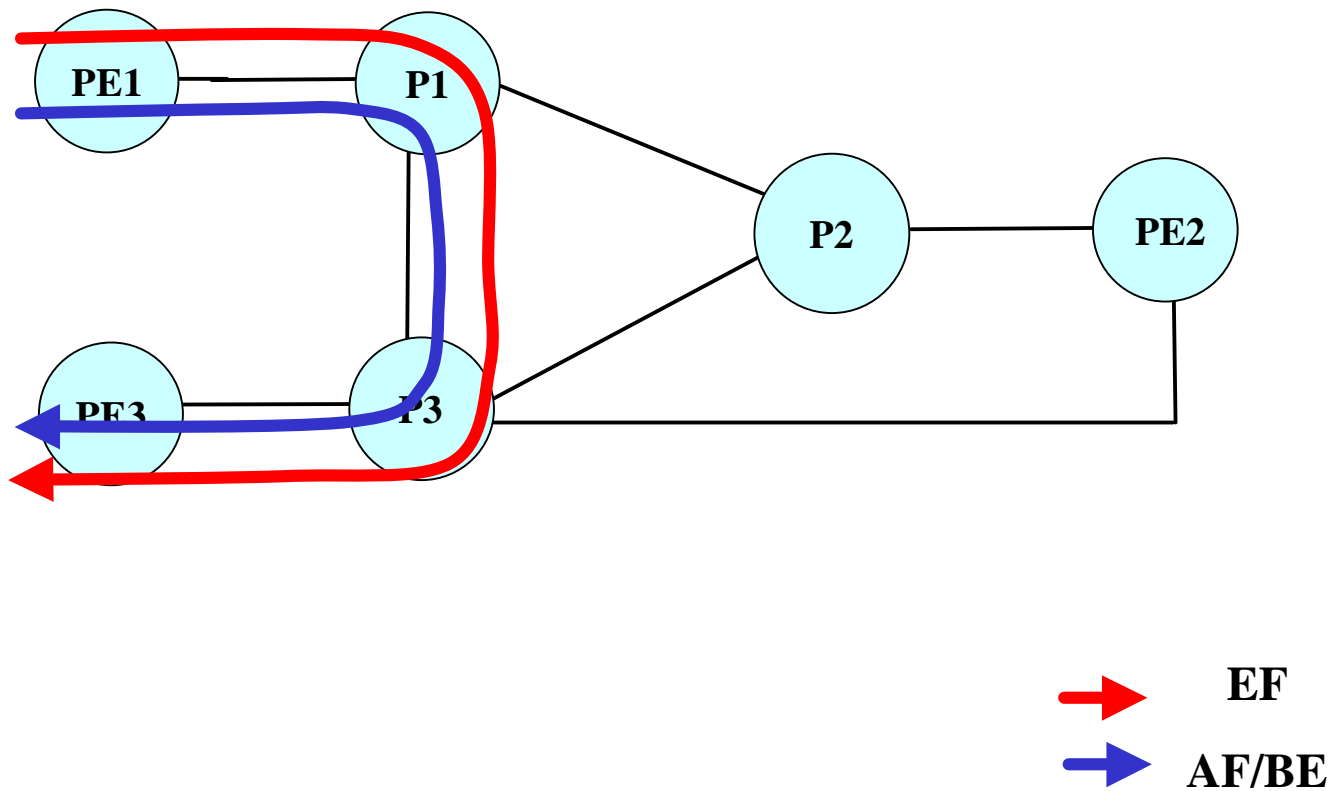



# One Way Delay for EF, AF1 & BE

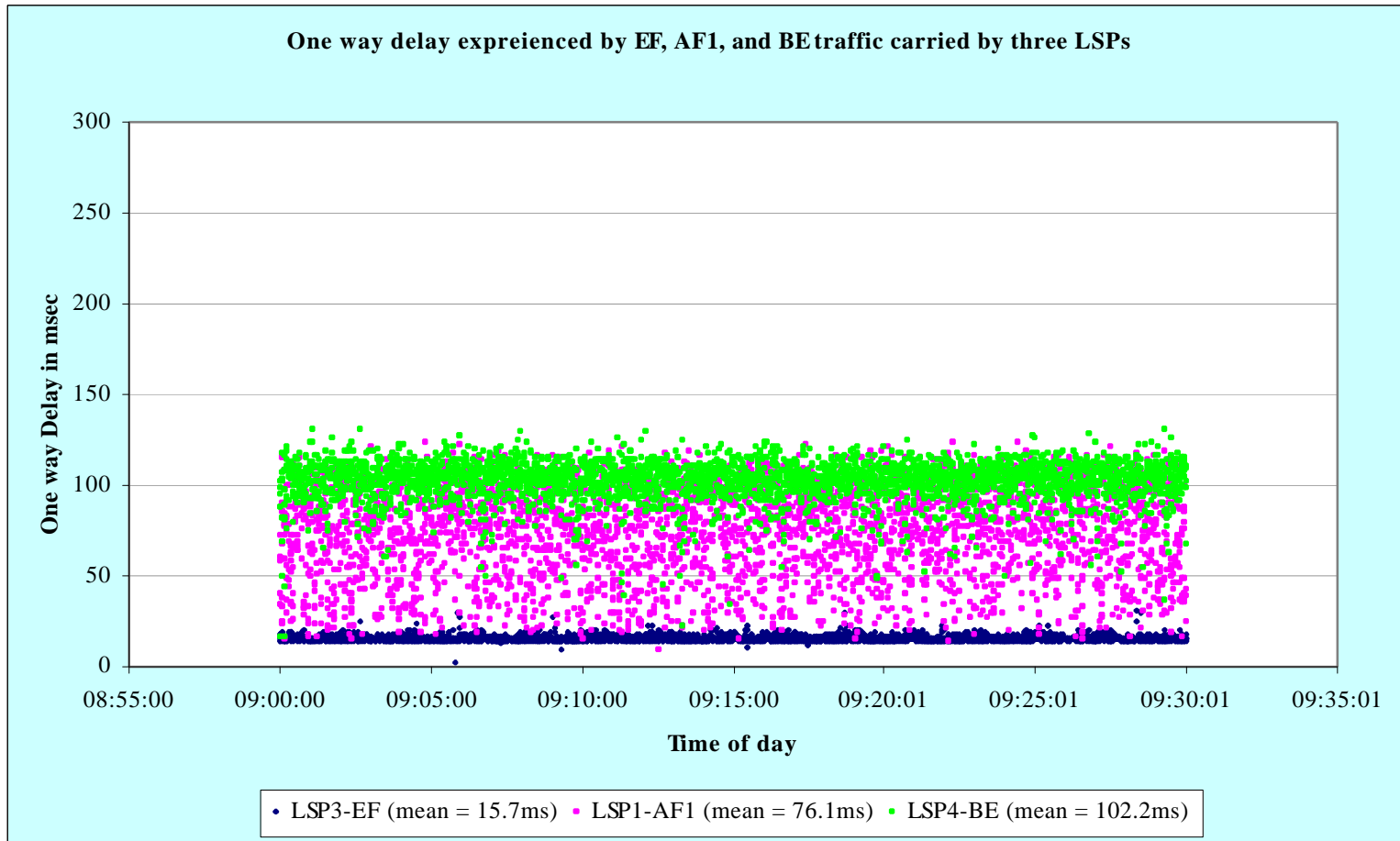



# Extrapolation of Customer Demand

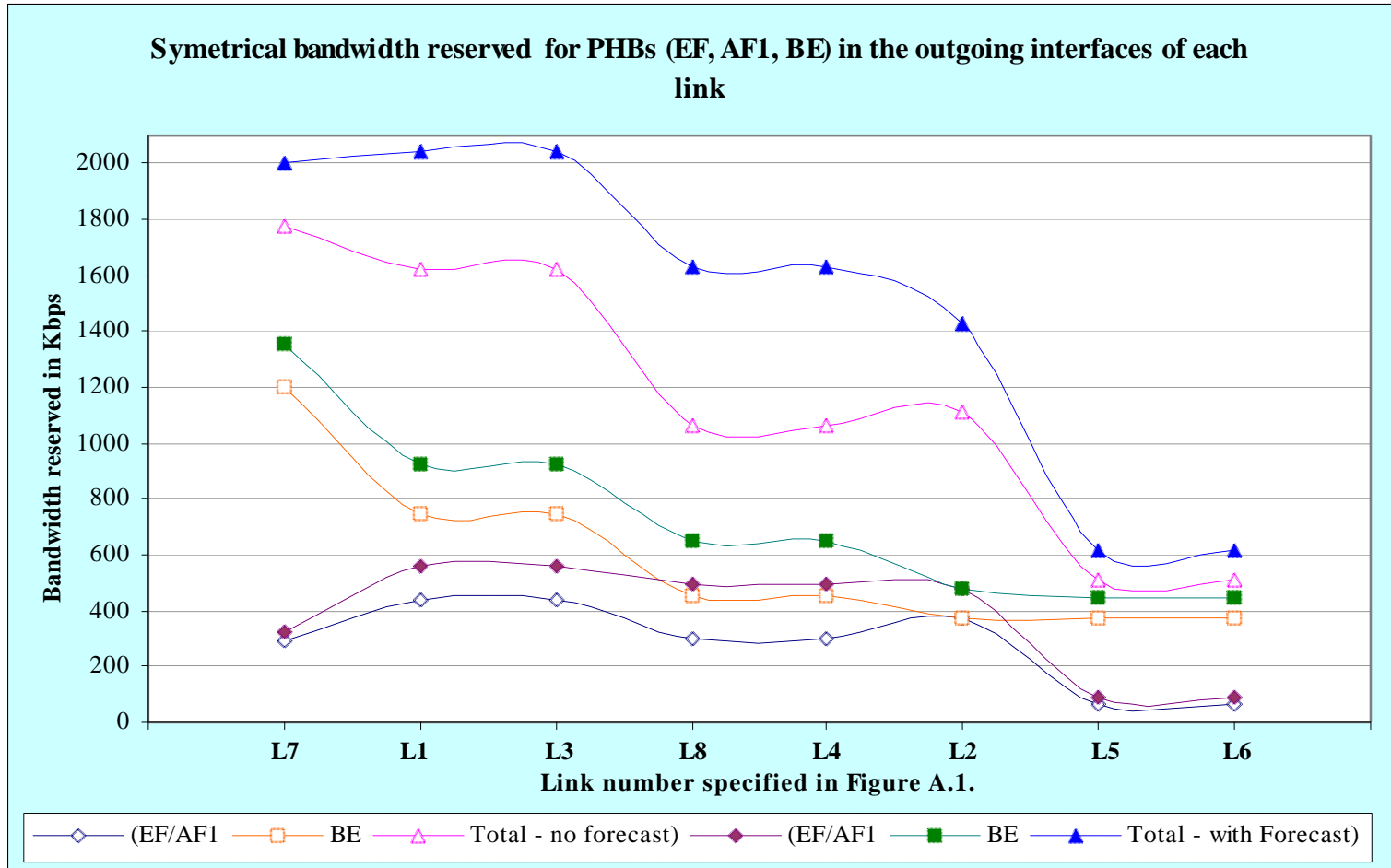



# One Way Loss for EF, AF & BE

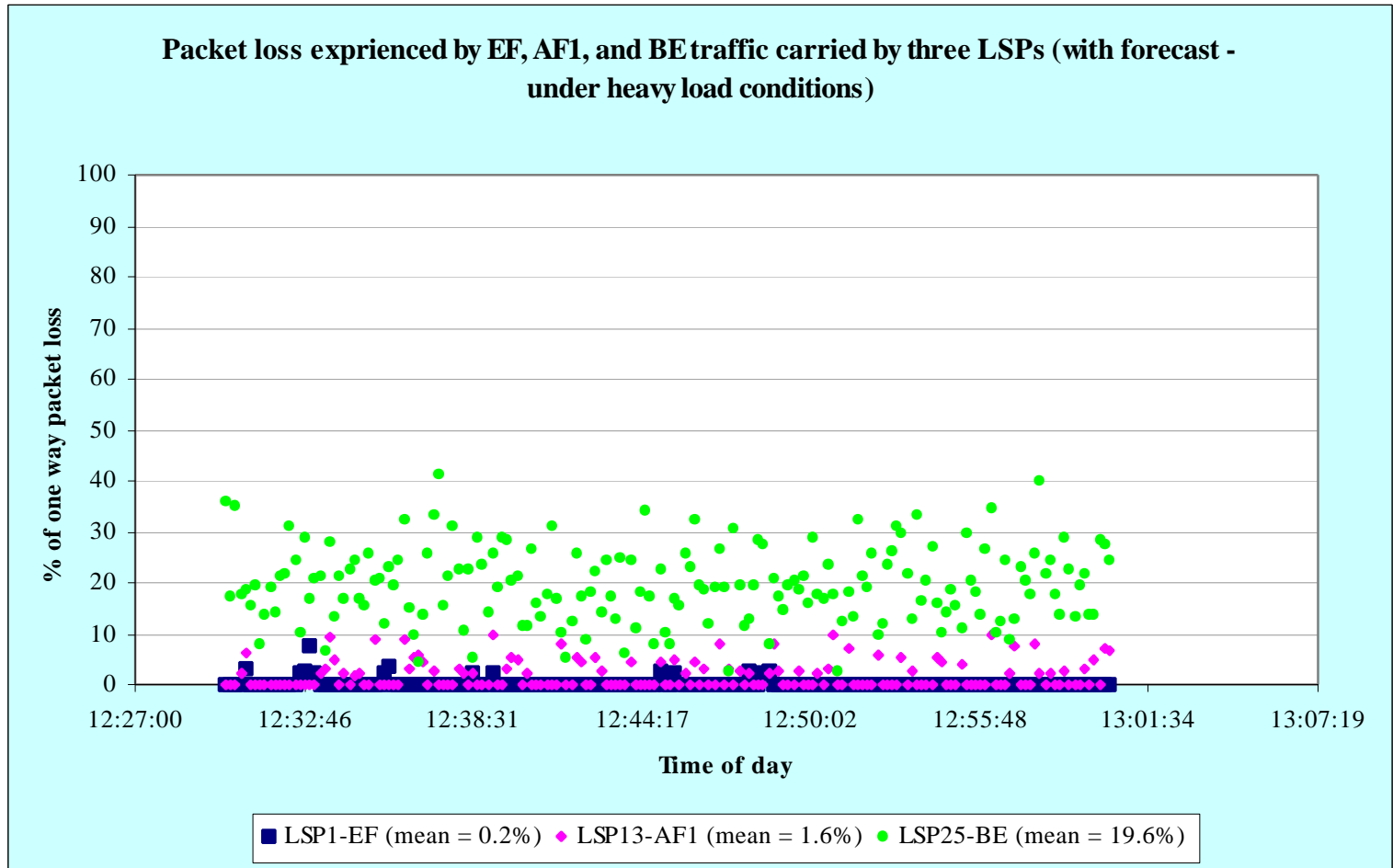

# Differentiated Service (Quantitative)

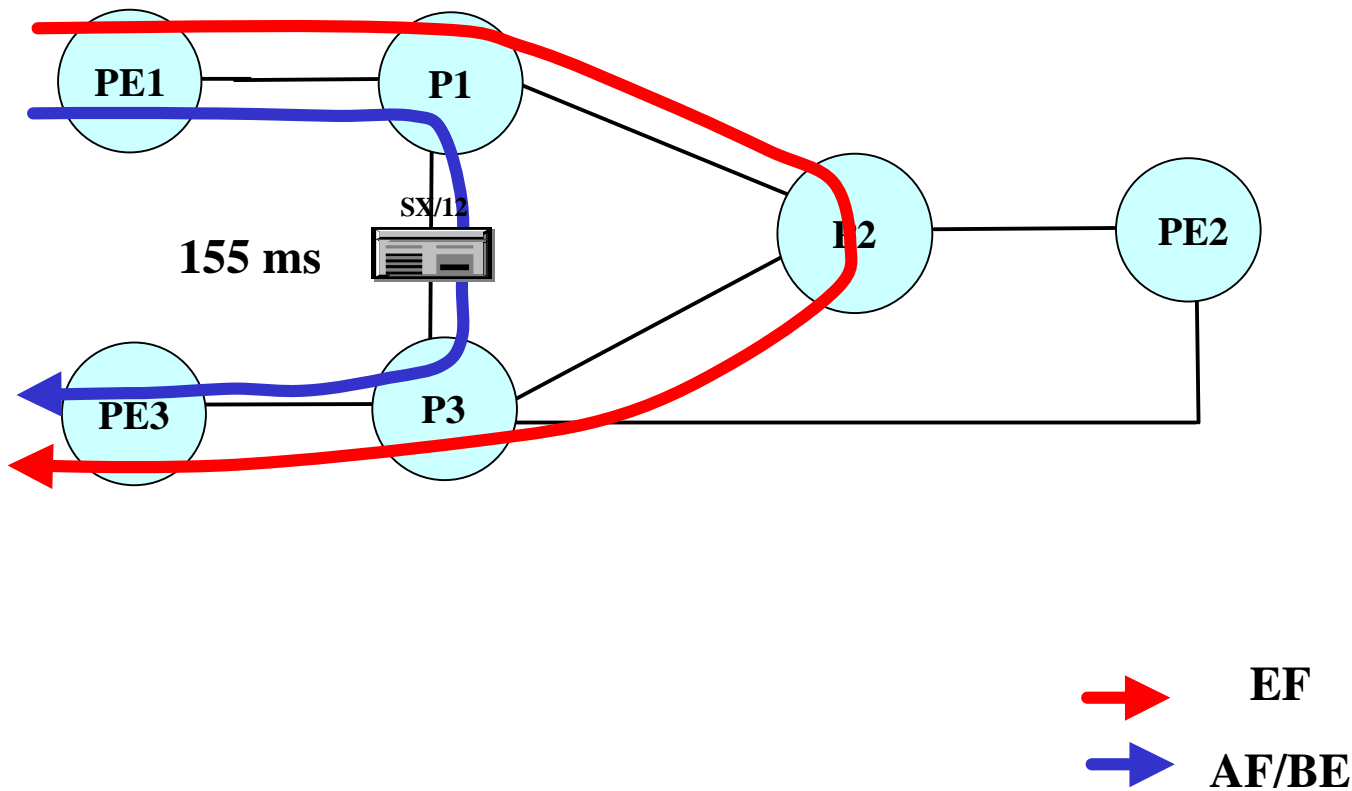



# One Way Delay for EF, AF1 & BE

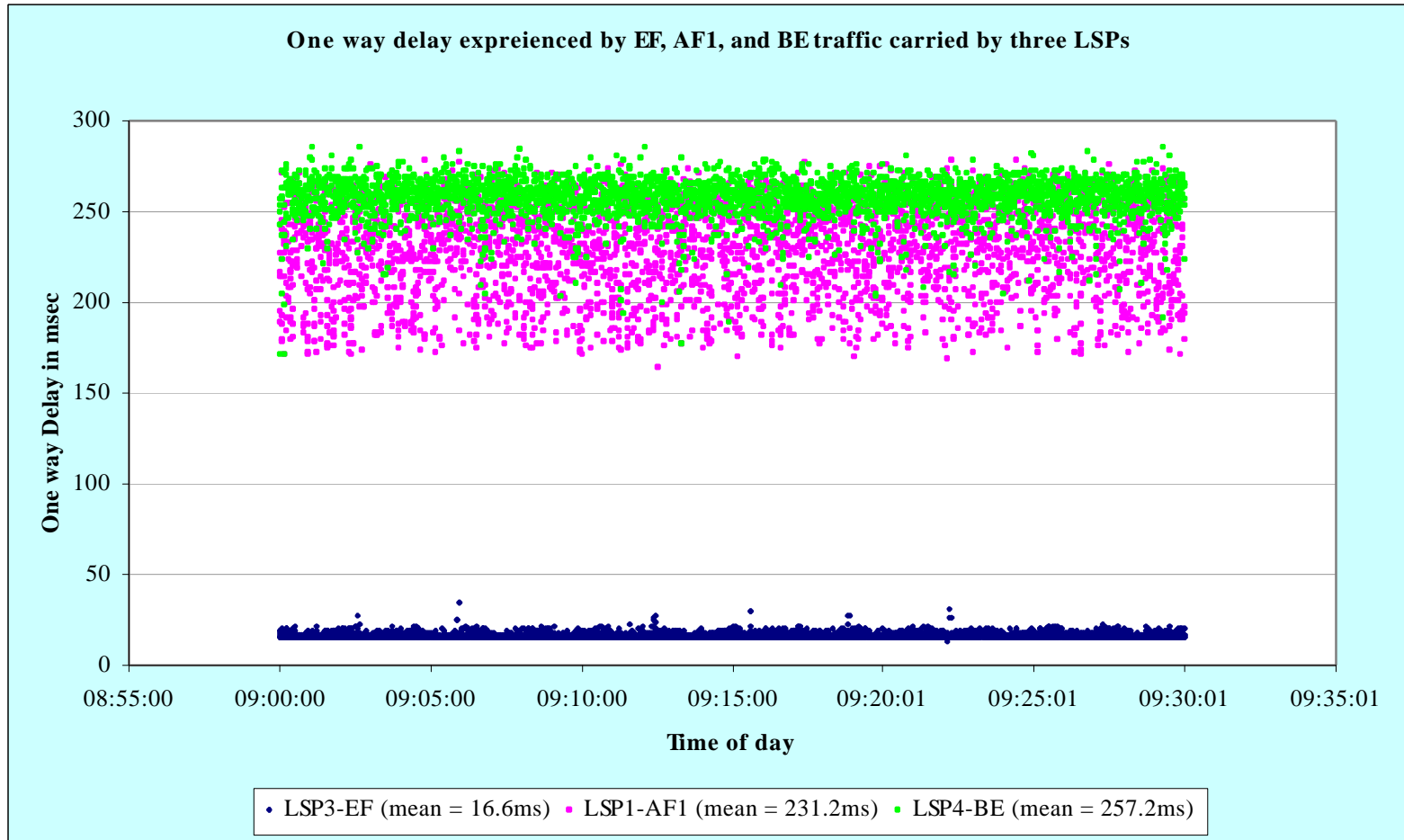



# Test Objective

---

- **Compare TEQUILA & Cisco's approach to MPLS-TE & DiffServ integration**
- **Cisco has automatic LSP set-up mechanism**
  - constraint (bandwidth) based routing
  - does not accept a delay constraint
- **Cisco does not have automatic PHB dimensioning**
- **Cisco's MPLS-TE & DiffServ technology is not integrated with Customer SLSs**

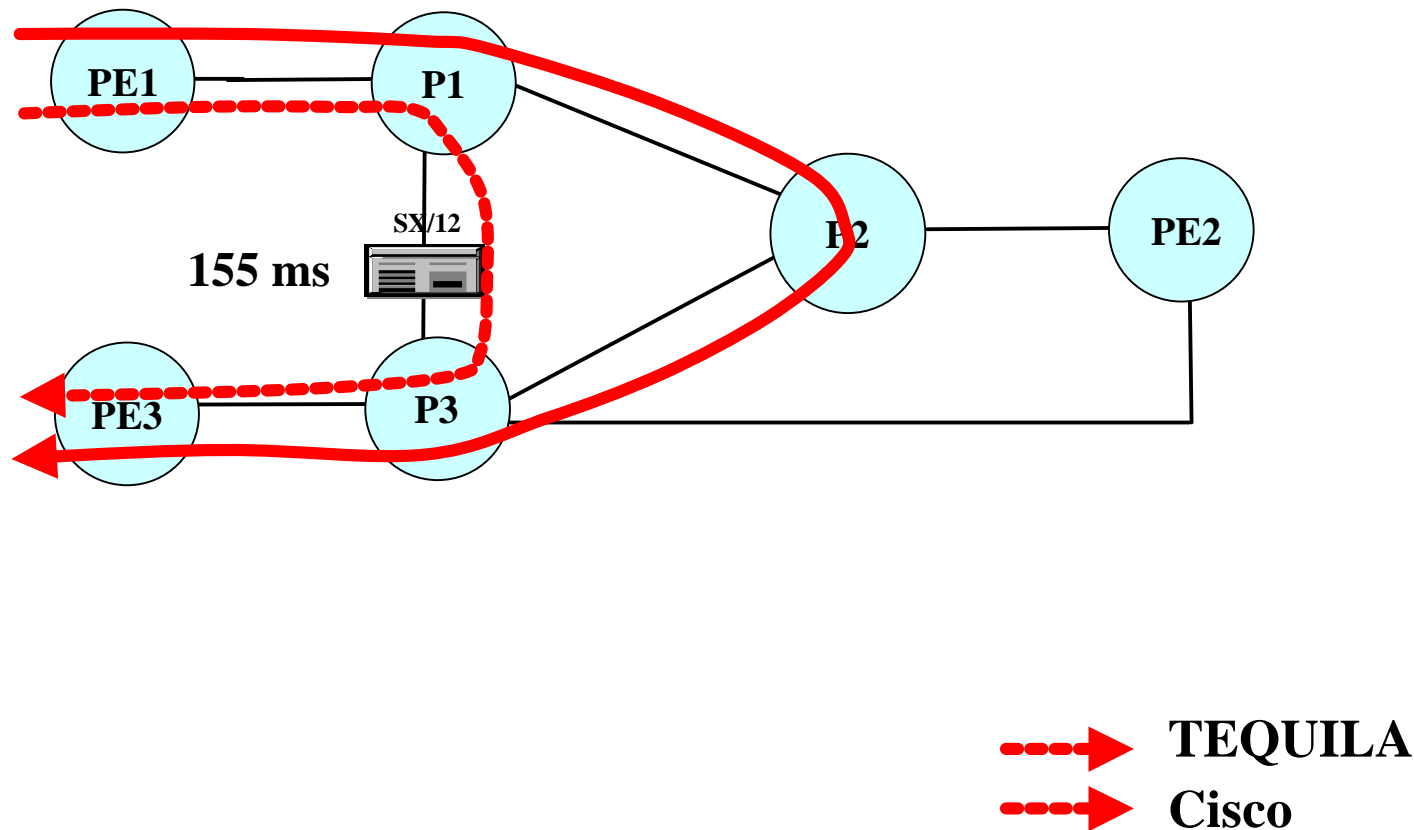



# One Way Delay for EF Traffic

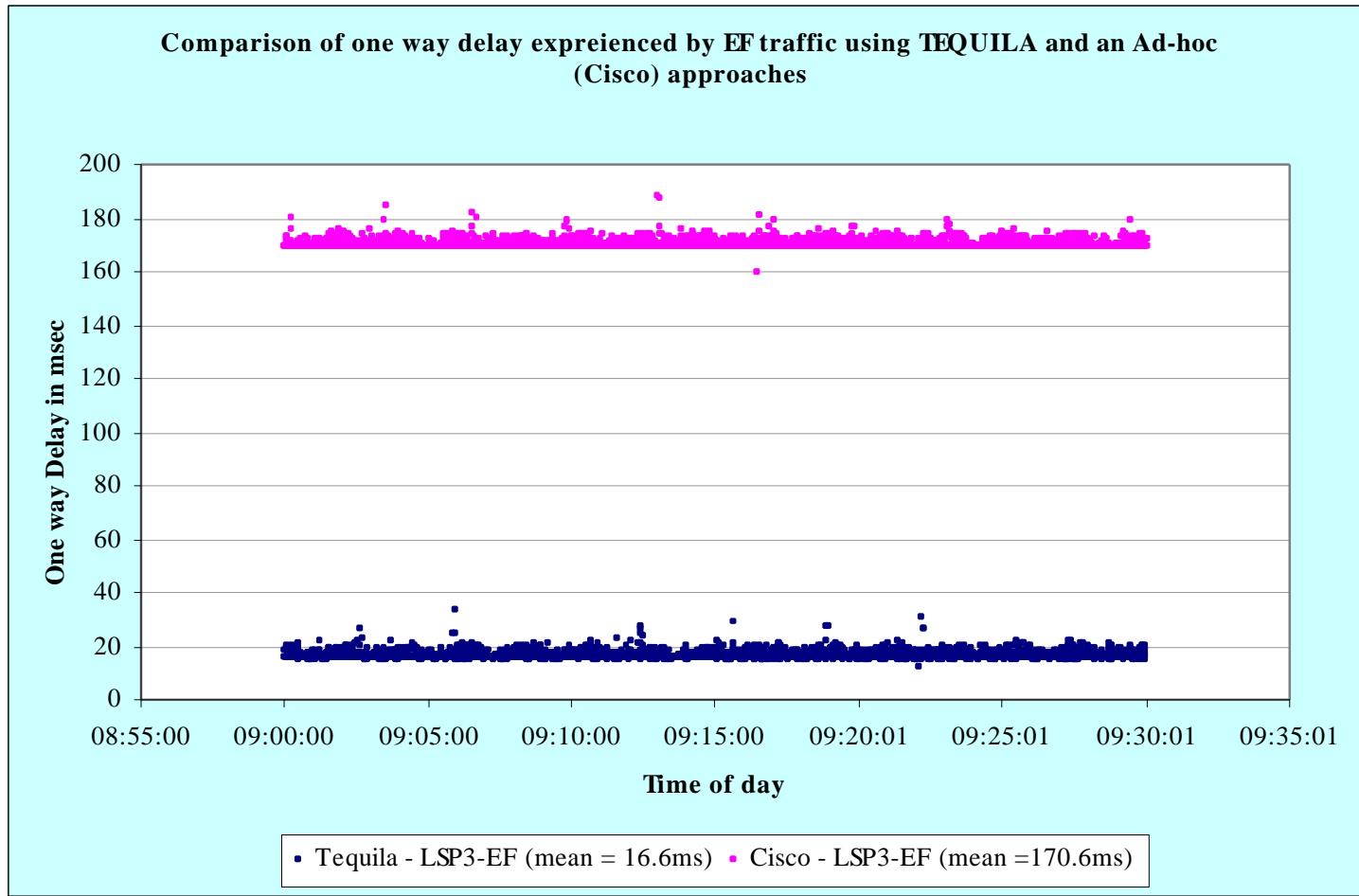



# Test Objective

---

- **Evaluate bandwidth allocation of TEQUILA algorithms for Pipe and Hose-based VPNS**
- **Create Hose/Pipe VPNs**
  - one each for EF, AF & BE
- **First Test - Pipe**
  - create 18 unidirectional pipes
- **Second Test - Hose**
  - created 9 unidirectional hoses

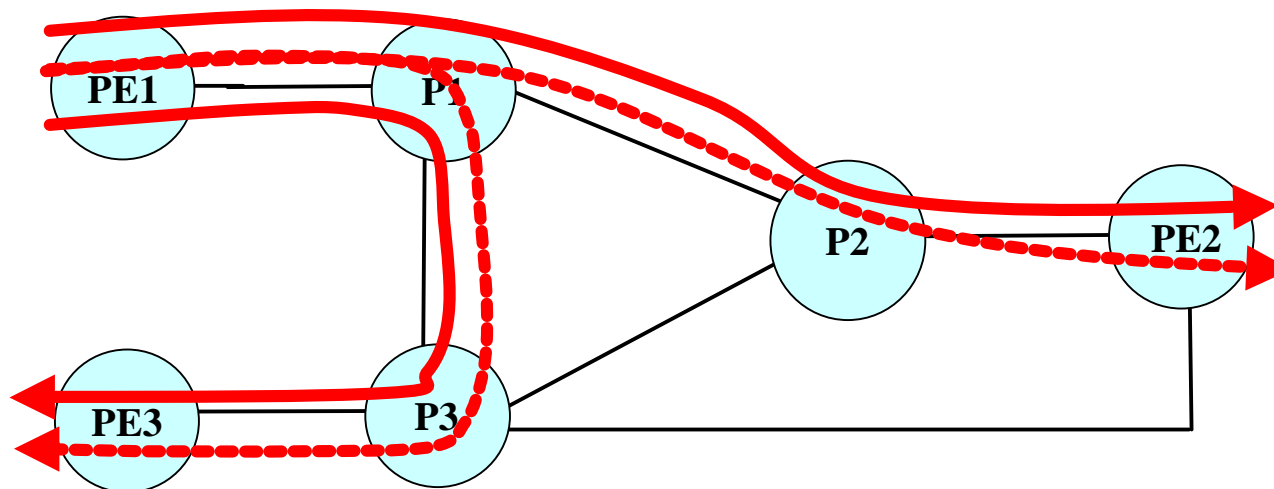



# Hose/Pipe - BW Allocation for EF

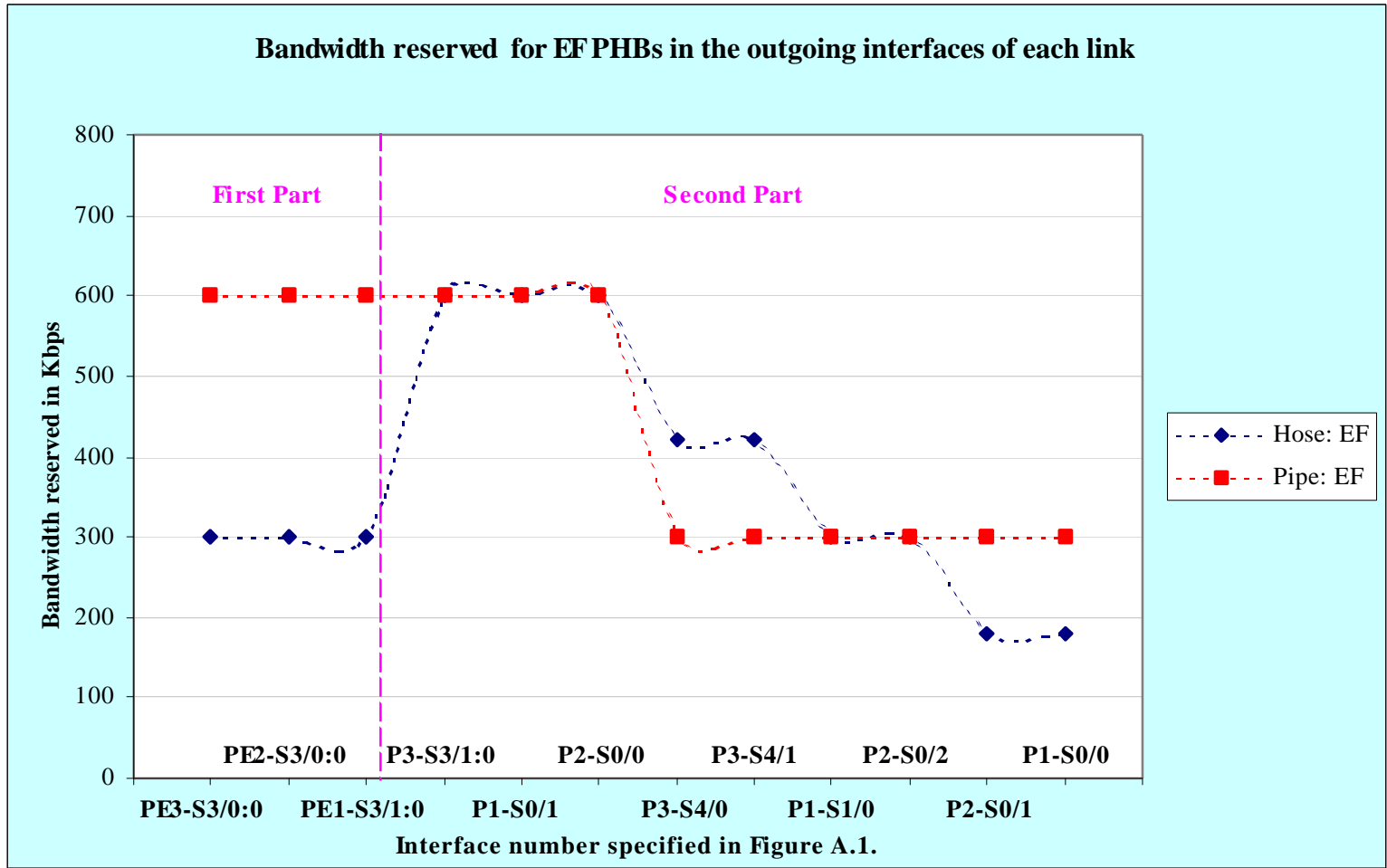



# Key Results

---

---

- **TEQUILA MPLS-TE delivers**
  - TE paths to meet user requirements
  - Differentiated Services - qualitative guarantees
  - Differentiated Services - quantitative guarantees (delay)
  - Load Balancing
  - Hose and Pipe-based VPNs
- **Commercial MPLS-TE**
  - Commercial equipment supports differentiated services, but
    - requires manual computation of TE paths
    - no automated PHB configuration
  - commercial solutions do not accept delay/loss constraints
  - lack of integration with customer SLSs
    - forecasting not available